

CATALOGUE

DISTRICT HEATING / COOLING PRE - INSULATED PIPE SYSTEMS



CONTENT

PIPEX
POLIURS

INTRODUCTION

1



2

GENERAL INFORMATION

3

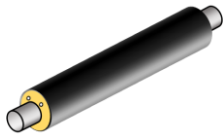

SINGLE PIPES / FITTINGS

4



TWIN PIPES / FITTINGS

5

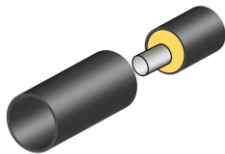

JOINTS

6

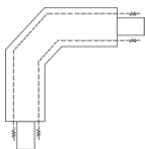

ALARM SYSTEM DESIGN

7



ACCESSORIES

8

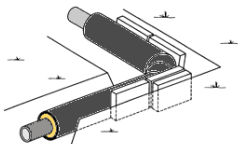

DESIGN GUIDELINES

9

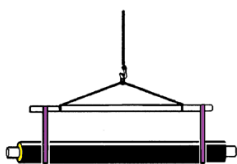

TRANSPORT AND STORAGE

INTRODUCTION



v.4.2025

1.0.



Currently for district heating networks the preinsulated pipes are most widely used. The main advantages of preinsulated pipes are:

- minimal heat losses;
- long service life (30-50 years) with minimal maintenance demands;
- simple assembly of joints, providing efficient thermal insulation and waterproofing;
- concrete duct is not necessary, pipes are laid in the trench on sand layer;
- electronic moisture surveillance system is available.

“POLIURS” Ltd. has specialized in the production of preinsulated pipes for district heating since January, 1995. Special attention is devoted towards high quality of the product and protection of surrounding environment. Developed quality system is certified according to standards ISO 9001 and ISO 14001. Introduced ISO 9001 and ISO 14001 Quality Management Systems ensure that the products of “POLIURS” Ltd. are manufactured according to the European standards:

- EN 253. District heating pipes - Pipe assembly of steel service pipes, polyurethane thermal insulation and outer casing of polyethylene.
- EN 448. District heating pipes - Fitting assemblies of steel service pipes, polyurethane thermal insulation and outer casing of polyethylene.
- EN 488. District heating pipes - Steel valve assembly for steel service pipes, polyurethane thermal insulation and outer casing of polyethylene.
- EN 489. District heating pipes - Joint assembly for steel service pipes, polyurethane thermal insulation and outer casing of polyethylene.
- EN 13941-1. Design and installation of thermal insulated bonded single and twin pipe systems for directly buried hot water networks - design.
- EN 13941-2. Design and installation of thermal insulated bonded single and twin pipe systems for directly buried hot water networks - installation.
- EN 14419. Surveillance system.
- EN 15698-1. Twin pipe systems, Part 1: Factory made fittings
- EN 15698-2. Twin pipe systems, Part 2: Factory made fittings and valve assemblies

In addition to traditional products described in catalogue “POLIURS” Ltd. offers individually designed pipes and fittings on the customer demand. Individual solutions can remarkably reduce the volume of installation works and the expenses required. Company’s staff consults customers in all aspects regarding optimal choice of pipe installation.

A preinsulated bonded pipe for district heating is a sandwich construction consisting of three main components:

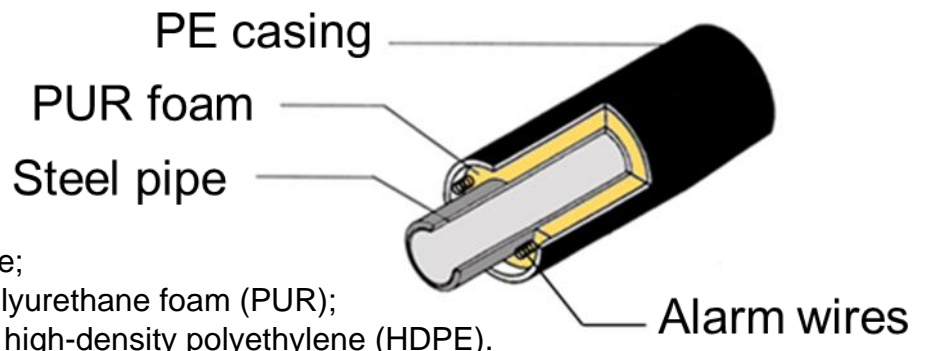

- a steel service pipe;
- an insulation of polyurethane foam (PUR);
- an outer casing of high-density polyethylene (HDPE).

“Poliurs” Ltd. produces preinsulated bonded pipes and their fittings with diameters of main service pipes from 20 to 1000 mm (3/4 - 39 inches). Depending on diameter of used casing pipe for each service pipe 4 different thicknesses of foam insulation layers are possible, 4 insulation series.

“Poliurs” Ltd. also produces preinsulated pipes and fittings for special application:

- preinsulated pipes and fittings with galvanized spiral steel casing;
- pipes and fittings with two-layer insulation for temperatures 150 - 250°C;
- preinsulated double pipes and fittings, where under one casing are located two pipes: preheated and return pipes;
- preinsulated pipes with heating cable.

Preinsulated pipes are equipped with alarm system wires that certify pipeline correspondence to the technical specifications when it becomes operational, also makes an operator known in case of a potential accident and discovers its exact location. The surveillance of the pipeline can be automatically. Assortment of preinsulated pipes and fittings enables to construct pipeline in complicated geographical region (including overcoming of water barriers) and in the cities.

On costumers’ request, the company can supply fittings of the individualized construction.

Different technical ways and means are offered for compensation of thermal expansion deformation and its effect decrease.

The company meets the customers’ needs concerning additional materials for the assembly of pipeline and fittings.

Company consults and train clients of necessary rules regarding pipe assembly, and offers technical surveillance of the pipeline installation (during assembly and acceptance of the pipeline).

GENERAL INFORMATION

2.1.

The company "POLIURS" Ltd. Quality Management System correspondingly to ISO 9001 demands includes all structural entities and staff, which are connected to the production of the heat insulated products and client relationship. The company uses only certified resources for production of pipes, fittings and its accessories. The staff of the company is qualified and certified. All main parameters of the production process are controlled and recorded; staff involved in the production is also registered. That way high level of responsibility is achieved. The personal responsibility for one's own duties is the main guarantee of the company's production.

ISO 9001 and ISO 14001 have been proved and certified by "Bureau Veritas Quality International" that is the leading world firm in certification.

"POLIURS" Ltd. guarantees that the operational time of the manufactured preinsulated bonded pipes and joints is 5 (five) years, if following conditions are fulfilled:

- comply with instructions for transportation, storage, assembly and operation, which are included in "Heating main montage instructions CV4.04."
- ensures following pipeline parameters:
 - working pressure $\leq 16; 25$ bar;
 - temperature $\leq 140^{\circ}\text{C}$;
 - salinity < 3000 mg/l;
 - pH 9,5 -10;
 - free oxygen not permissible.

The company "POLIURS" Ltd. provides its consumers with the special quality certificate on all their products.

"POLIURS" Ltd. is constantly working on widening its assortment of produced items, improving product quality and offered services.

RISE (formerly SP) tests our products once per year on the basis of the functional requirements in EN 253 and the Euroheat & Power certification guidelines.



All steel service pipes, pipe casings and insulation material used in assembly of preinsulated pipes and fittings comply with European Standard - EN 253.

Main parameters:

1. Steel service pipe:

- nominal diameters DN: 20 - 1000 mm;
- steel grades P235GH EN 10217-2 and P235TR1/2 EN 10217-1;
- upper yield strength, min: 235 MPa;
- tensile strength, min: 360 - 500 MPa.

Steel pipe	Outer diameter	Nominal wall thickness
DN	[mm]	[mm]
20	26,9	2,0
25	33,7	2,6
32	42,4	2,9
40	48,3	2,9
50	60,3	2,9
65	76,1	2,9
80	88,9	3,2
100	114,3	3,6
125	139,7	3,6
150	168,3	4,0
200	219,1	4,5
250	273,0	5,0
300	323,9	5,6
350	355,6	5,6
400	406,4	6,3
450	457,0	6,3
500	508,0	6,3
600	610,0	7,1
700	711,0	8,0
800	813,0	8,8
900	914,0	10,0
1000	1016,0	11,0
1100	1120,0	11,0

2. Pipe casings:

- material: HDPE PE100;
- wall thickness according to EN 253;
- minimum density: 944 kg/m³.

Diameter [mm]	Minimum wall thickness [mm]
90	3,0
110	3,0
125	3,0
140	3,0
160	3,0
180	3,0
200	3,2
225	3,4
250	3,6
280	3,9
315	4,1
355	4,5
400	4,8
450	5,2
500	5,6
560	6,0
630	6,6
710	7,2
800	7,9
900	8,7
1000	9,4
1100	10,2
1200	11,0
1300	12,5

3. Thermal insulation:

- material: PUR (polyurethane foam);
- PUR components: polyol and isocyanate;
- blowing agent: CYCLOPENTANE;
- conductivity max.: 0.026 W/m^{°K}

SINGLE PIPES / FITTINGS

3.0.



Pipes

3.1.1. – 3.1.7.



Bends

3.2.1. – 3.2.2

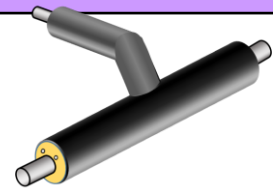

T-pieces

3.3.1. – 3.3.5.

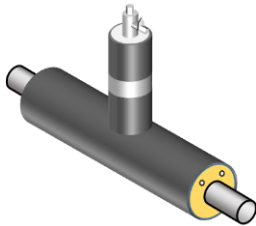

Air vent/drain units

3.3.6. – 3.3.7.

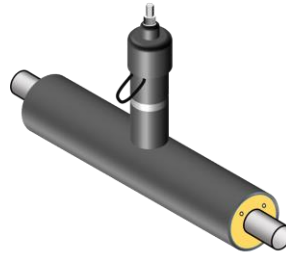

Valves

3.4.1.

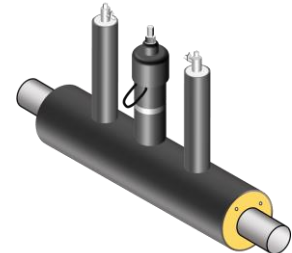

**Valves with
air vent/drain units**

3.4.2. – 3.4.4.

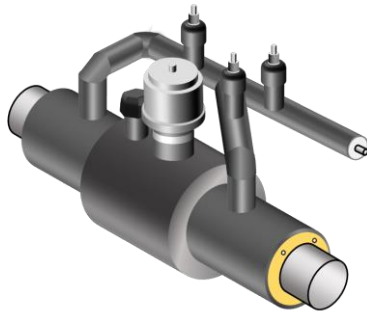

Bypass valves

3.4.5. – 3.4.7.

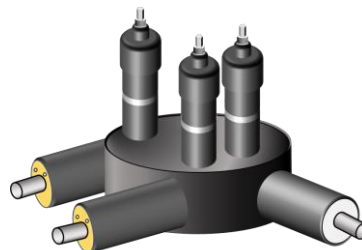

Compact valves

3.4.8.

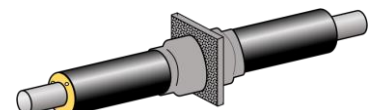

Fixed anchors

3.5.1.



Compensators

3.5.2.

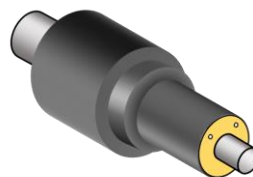

Diameter reducers

3.5.3.

Preinsulated single pipes

3.1.1.

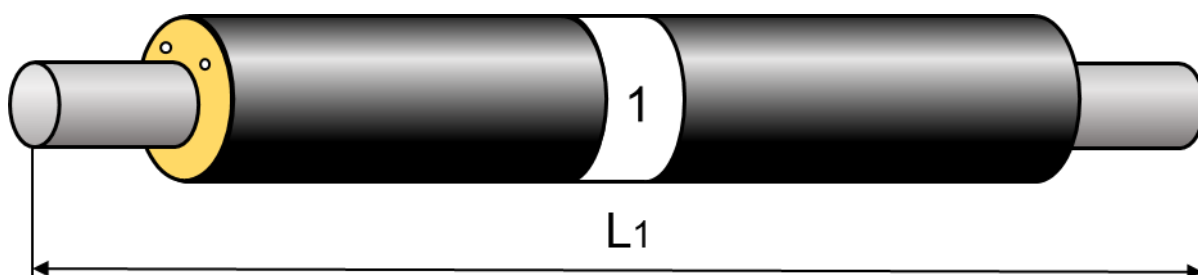

Series 1

Main pipe DN	PE casing pipe [mm]	Weight [kg/m]	Water content [l/m]	Transfer capacity $\Delta T = 50\text{ }^{\circ}\text{C}$ [kW]
20	90	2,4	0,4	65
25	90	3,1	0,6	100
32	110	4,3	1,1	180
40	110	4,6	1,5	230
50	125	6,1	2,3	370
65	140	7,4	3,5	700
80	160	9,4	5,3	1 000
100	200	13,6	9,0	1 800
125	225	16,6	13,8	3 300
150	250	21,5	20,2	5 000
200	315	31,9	34,7	10 000
250	400	43,9	54,3	18 000
300	450	60,0	76,8	28 000
350	500	68,3	93,1	34 000
400	560	86,9	121,7	45 000
450	630	101,0	155,0	65 000
500	710	105,4	193,0	80 000
600	800	138,0	277,0	110 000
700	900	190,2	378,0	160 000
800	1000	246,0	497,0	210 000
900	1100	276,0	627,0	265 000
1000	1200	342,0	776,0	330 000

Pipe length L_1 can be ordered 6; 12; 16; 18 m.

Material of service pipe - steel. On request - copper or stainless steel.

Material of casing pipe - high density polyethylene (PE100).

Preinsulated single pipes

3.1.2.

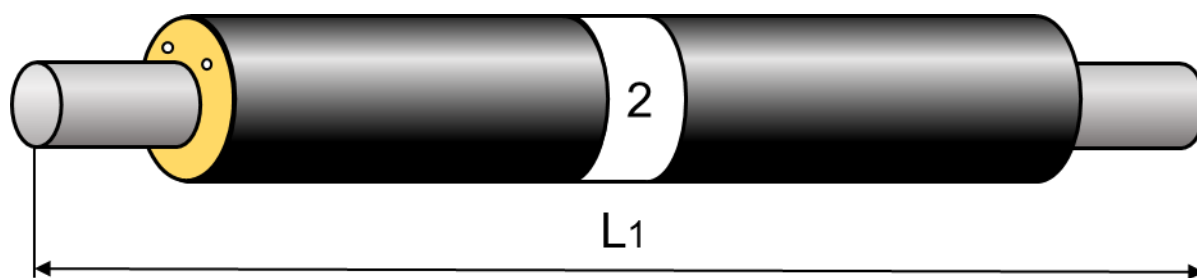

Series 2

Main pipe DN	PE casing pipe [mm]	Weight [kg/m]	Water content [l/m]	Transfer capacity $\Delta T = 50\text{ }^{\circ}\text{C}$ [kW]
20	110	3,3	0,4	65
25	110	3,5	0,6	100
32	125	4,6	1,1	180
40	125	5,0	1,5	230
50	140	6,5	2,3	370
65	160	8,0	3,5	700
80	180	10,1	5,3	1 000
100	225	14,8	9,0	1 800
125	250	17,7	13,8	3 300
150	280	23,6	20,2	5 000
200	355	35,1	34,7	10 000
250	450	47,0	54,3	18 000
300	500	65,5	76,8	28 000
350	560	75,7	93,1	34 000
400	630	96,3	121,7	45 000
450	710	113,5	155,0	65 000
500	800	118,0	193,0	80 000
600	900	153,6	277,0	110 000
700	1000	210,0	378,0	160 000
800	1100	267,0	497,0	210 000
900	1200	305,6	627,0	265 000

Pipe length **L1** can be ordered 6; 12; 16; 18 m.

Material of service pipe - steel. On request - copper or stainless steel.

Material of casing pipe - high density polyethylene (HDPE).

Preinsulated single pipes

3.1.3.

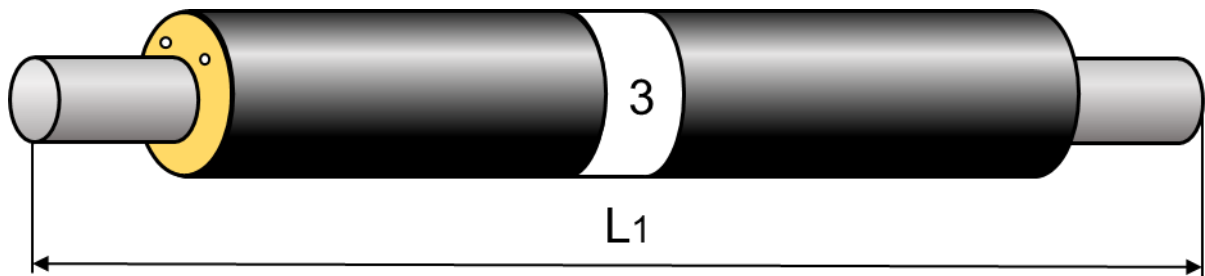

Series 3

Main pipe DN	PE casing pipe [mm]	Weight [kg/m]	Water content [l/m]	Transfer capacity $\Delta T = 50\text{ }^{\circ}\text{C}$ [kW]
20	125	3,7	0,4	65
25	125	3,9	0,6	100
32	140	5,0	1,1	180
40	140	5,4	1,5	230
50	160	7,1	2,3	370
65	180	8,7	3,5	700
80	200	10,9	5,3	1 000
100	250	16,2	9,0	1 800
125	280	19,9	13,8	3 300
150	315	25,7	20,2	5 000
200	400	39,0	34,7	10 000
250	500	51,4	54,3	18 000
300	560	76,9	76,8	28 000
350	630	85,1	93,1	34 000
400	710	108,8	121,7	45 000
450	800	124,0	155,0	65 000
500	900	147,0	193,0	80 000
600	1000	189,0	277,0	110 000
700	1100	248,0	378,0	160 000
800	1200	289,0	497,0	210 000

Pipe length **L1** can be ordered 6; 12; 16; 18 m.

Material of service pipe - steel. On request - copper or stainless steel.

Material of casing pipe - high density polyethylene (HDPE).

Preinsulated single pipes

3.1.4.

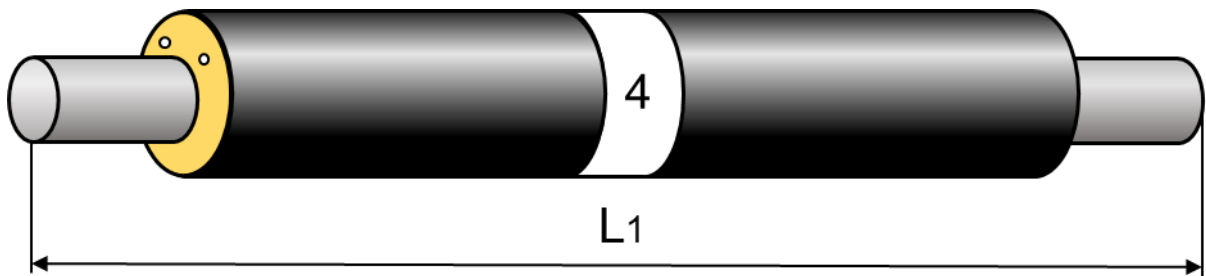

Series 4

Main pipe DN	PE casing pipe D [mm]	Weight [kg/m]	Water content [l/m]	Transfer capacity $\Delta T = 50\text{ }^{\circ}\text{C}$ [kW]
20	140	4,1	0,4	65
25	140	4,4	0,6	100
32	160	5,5	1,1	180
40	160	6,0	1,5	230
50	180	7,8	2,3	370
65	200	9,6	3,5	700
80	225	11,9	5,3	1 000
100	280	17,4	9,0	1 800
125	315	22,5	13,8	3 300
150	355	28,0	20,2	5 000
200	450	42,0	34,7	10 000
250	560	56,6	54,3	18 000
300	630	82,5	76,8	28 000
350	710	93,5	93,1	34 000
400	800	119,0	121,7	45 000
450	900	139,0	155,0	65 000
500	1000	162,0	193,0	80 000
600	1100	207,0	277,0	110 000
700	1200	259,0	378,0	160 000

Pipe length L_1 can be ordered 6; 12; 16; 18 m.

Material of service pipe - steel. On request - copper or stainless steel.

Material of casing pipe - high density polyethylene (HDPE).

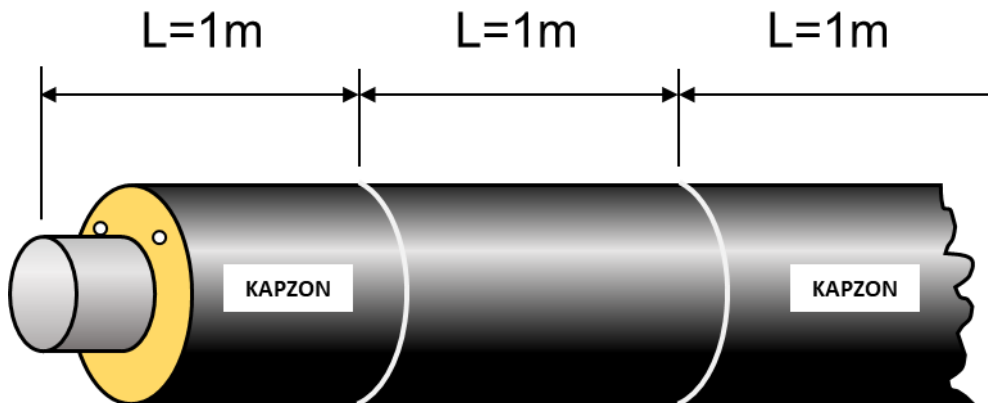

Series 1, 2, 3 and 4

Steel service pipe is covered by a plastic foil every second meter along the entire pipe length. This arrangement allows easy removal of the foam from the steel in the sections which are indicated on the outside casing pipe. Whole lengths or parts of pipes cut-to-length can be installed at any place.

L1 segments can be ordered on 6; 12; 16; 18 m long pipes.

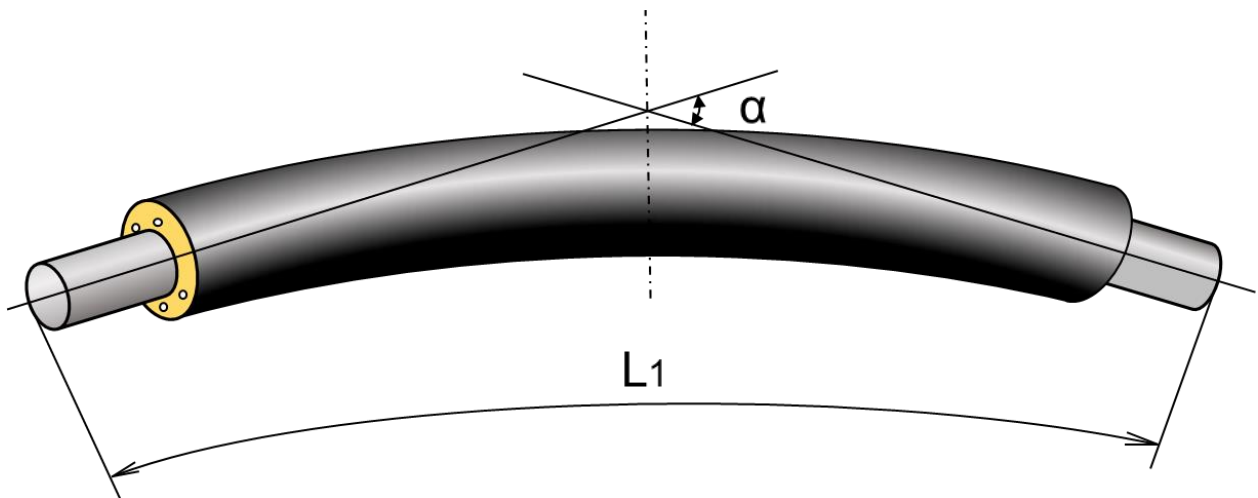

Series 1, 2, 3 and 4

Main pipe DN	Max deflection angle L1= 12m	Max deflection angle L1 = 16m
25 – 50	45°	45°
50 – 80	45°	45°
100 – 150	45°	45°
200 – 250	26°	26°
300-400	16°	16°
500	9°	9°

Allowable accuracy: DN 25 - 80 mm +/- 3°

DN 100 - 250 mm +/- 2°

DN 300 - 500 mm +/- 1°

Straight section at each end of the pipe is 2.0m

Upon request, pipe can be bent in 3, 5 or 9 places.

Pipes with two-layer insulation (150 – 250 °C)

3.1.7.

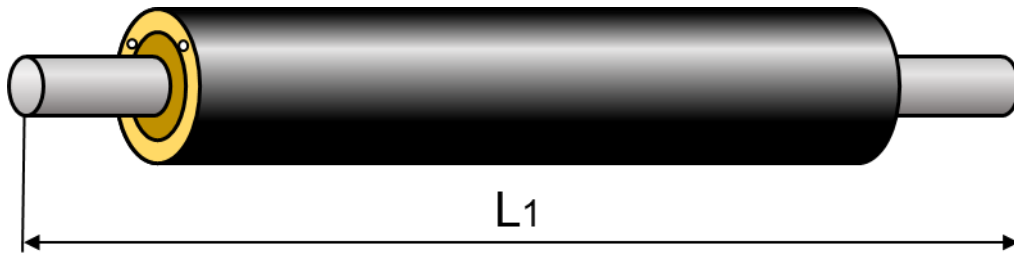

Main pipe DN	PE casing pipe [mm]			
	Series 1	Series 2	Series 3	Series 4
20	125	140	160	180
25	125	140	160	180
32	140	160	180	200
40	140	160	180	200
50	160	180	200	225
65	180	200	225	250
80	200	225	250	280
100	250	280	315	355
125	280	315	355	400
150	315	355	400	450
200	400	450	500	560
250	450	500	560	630
300	500	560	630	710
350	560	630	710	800
400	630	710	800	900

Custom made product.

Insulation:

- inner rock wool layer
- outer layer of polypropylene (PUR) foam.

Pipe length **L1** can be ordered 6; 12; 16; 18 m.

Preinsulated bend

3.2.1.

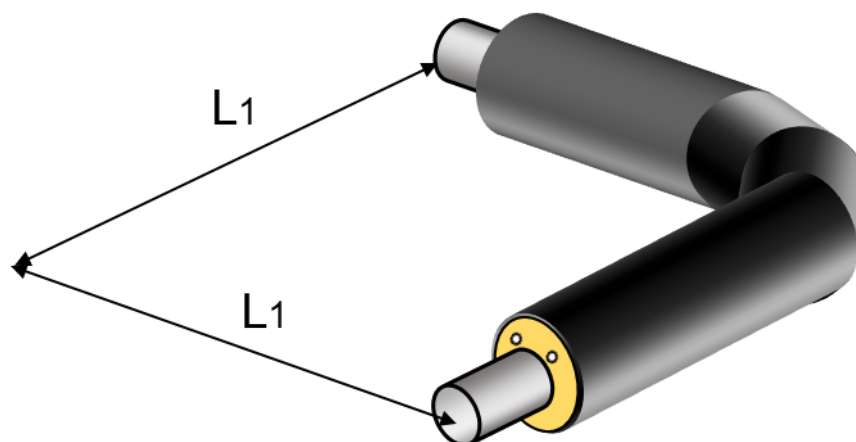

Main pipe DN	PE casing pipe [mm]				L1 [mm]
	Series 1	Series 2	Series 3	Series 4	
20	90	110	125	140	1000
25	90	110	125	140	1000
32	110	125	140	160	1000
40	110	125	140	160	1000
50	125	140	160	180	1000
65	140	160	180	200	1000
80	160	180	200	225	1000
100	200	225	250	280	1000
125	225	250	280	315	1000
150	250	280	315	355	1000
200	315	355	400	450	1000
250	400	450	500	560	1300
300	450	500	560	630	1500
350	500	560	630	710	1600
400	560	630	710	800	1600
450	630	710	800	900	1600
500	710	800	900	1000	1600
600	800	900	1000	1100	1600
700	900	1000	1100	1200	1700

Standard bends $\alpha = 90^\circ$.

Cut back length of bends:

Dn20-125 = 0.5m

Dn150-250 = 0.7m

Dn300-500 = 1.0m

Preinsulated vertical bends

3.2.2.

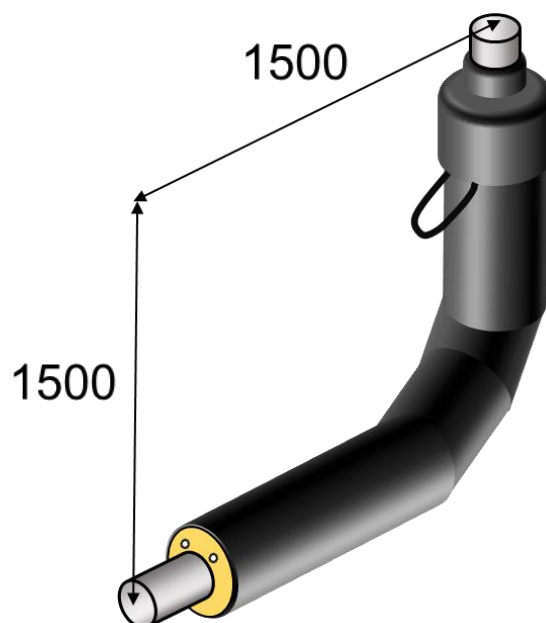

Main pipe DN	PE casing pipe [mm]			
	Series 1	Series 2	Series 3	Series 4
20	90	110	125	140
25	90	110	125	140
32	110	125	140	160
40	110	125	140	160
50	125	140	160	180
65	140	160	180	200
80	160	180	200	225
100	200	225	250	280
125	225	250	280	315
150	250	280	315	355
200	315	355	400	450
250	400	450	500	560
300	450	500	560	630
350	500	560	630	710
400	560	630	710	800
450	630	710	800	900
500	710	800	900	1000
600	800	900	1000	1100
700	900	1000	1100	1200

Vertical bends are most commonly used for heating pipeline entering the buildings.

Bends with length up to 10.0 m are made upon the request.

Can be ordered without an end cap.

Preinsulated perpendicular T-branches

3.3.1.

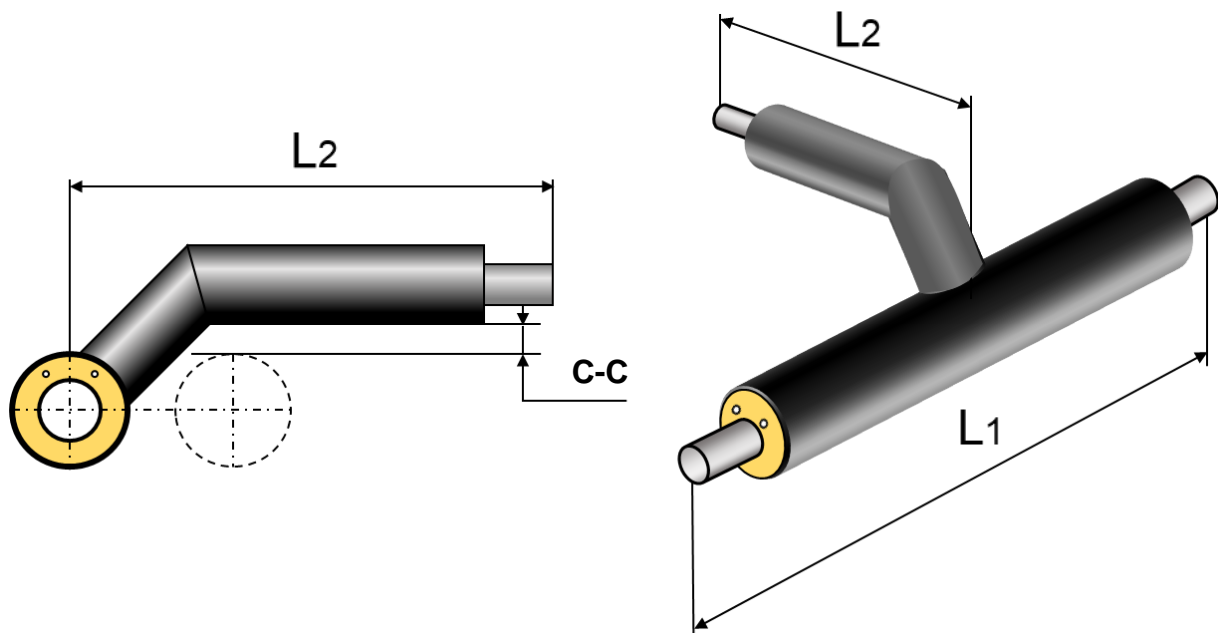

Series 1, 2, 3 and 4

Main pipe DN	Branch pipe D2	L1 [mm]	L2 [mm]
25 – 200	20 – 80	1200	1000
100 – 200	100 – 200	1500	1000
250 – 1000	25 – 80	1200	1200
250 – 1000	100 – 200	1500	1200
250 – 1000	250 – 400	1800	1500
600 – 1000	500 – 1000	2100	2100

Diameter of branch **L2** cannot be greater than diameter of main pipe **L1**.

T-pieces can be made upon the request:

- with a custom angle of branch pipe to the main pipe.

Steel pipe and forged T-piece thickness

Designed pressure of PN16 bar, calculated according to EN 13480-3

Designed temperature of 120°C

Steel pipes P235GH acc to EN 100217-2

Run pipe	Branch pipe															
	20	25	32	40	50	65	80	100	125	150	200	250	300	400	500	
20	TT2.3x2.3															
25	TT2.6x2.3	TT2.6x2.6														
32	2.9	TT2.6x2.6	TT2.6x2.6													
40	2.6	TT2.6x2.6	TT2.6x2.6	TT2.6x2.6												
50	→	2.9	TT2.9x2.6	TT2.9x2.6	TT2.9x2.9											
65	→	→	2.9	3.2	TT2.9x2.9	TT2.9x2.9										
80	→	→	→	3.2	3.6	TT3.2x2.9	TT3.2x3.2									
100	→	→	→	→	3.6	4.0	TT3.6x3.2	TT3.6x3.6								
125	→	→	→	→	→	3.6	4.0	TT5.0x4.5	TT5.0x5.0							
150	→	→	→	→	→	→	4.0	4.5	TT5.6x5.0	TT5.6x5.6						
200	→	→	→	→	→	→	→	4.5	<u>4.5</u>	TT7.1x5.6	TT7.1x7.1					
250	→	→	→	→	→	→	→	5.0	<u>5.0</u>	<u>5.0</u>	<u>5.0</u>	TT8.8x7.1	TT8.8x8.8			
300	→	→	→	→	→	→	→	5.6	<u>5.6</u>	<u>5.6</u>	<u>5.6</u>	<u>5.6</u>	TT10x10	TT10x10		
400	→	→	→	→	→	→	→	→	→	6.3	<u>6.3</u>	<u>6.3</u>	<u>6.3</u>	TT10x8.8	TT10x10	
500	→	→	→	→	→	→	→	→	→	6.3	<u>6.3</u>	<u>6.3</u>	<u>6.3</u>	<u>6.3</u>	TT10x8.8	TT11x11

TT – forged T-piece thickness

4.0 – run pipe thickness

4.0 – reinforcement is required, where L is reinforcement width and s1 is equal to thickness in table for each combination

→ – use value to the right

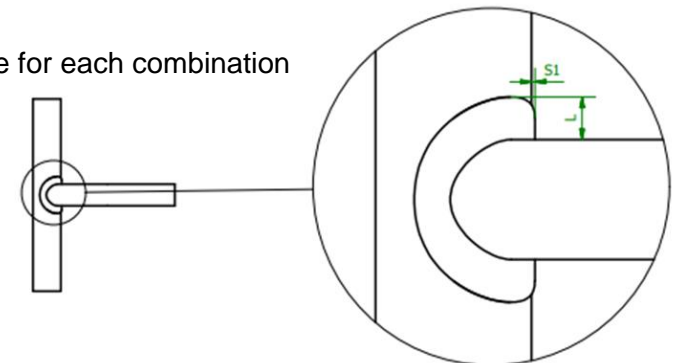

T-piece dimensions. Series 1

Main pipe		Branch pipe d2, series 1																
		26.9	33.7	42.4	48.3	60.3	76.1	88.9	114.3	139.7	168.3	219.1	273.0	323.9	355.6	406.4	457.0	508.0
DN/D1	L1, mm	Length L2, mm																
		C- C, mm																
26.6/90	1000	700																
		170																
33.7/90	1000	700	700															
		170	170															
42.4/110	1000	700	700	700														
		178	178	185														
48.3/110	1000	700	700	700	700													
		178	178	185	185													
60.3/125	1200	700	700	700	700	700												
		185	185	193	193	200												
76.1/140	1200	700	700	700	700	700	700											
		195	195	203	203	210	220											
88.9/160	1200	700	700	700	700	700	700	700										
		205	205	213	213	220	230	240										
114.3/200	1200	700	700	700	700	700	800	800	800									
		228	228	235	235	243	253	263	285									
139.7/225	1200	700	700	700	700	800	800	800	800	900								
		240	240	248	248	255	265	275	298	310								
168.3/250	1200	800	800	800	800	800	800	800	900	900	900							
		255	255	263	263	270	280	290	313	325	340							
219.1/315	1500	800	800	800	800	800	800	800	900	900	900	1000						
		293	293	300	300	308	318	328	350	363	378	415						
273.0/400	1500	800	800	800	800	900	900	900	900	1000	1000	1100	1200					
		340	340	348	348	355	365	375	398	410	425	463	510					
323.9/450	1500	900	900	900	900	900	900	900	1000	1000	1000	1100	1200	1200				
		365	365	373	373	380	390	400	423	435	450	488	535	560				
355.6/500	1500	900	900	900	900	900	900	900	1000	1000	1000	1100	1200	1200	1300			
		395	395	403	403	410	420	430	453	465	480	518	565	590	620			
406.4/560	1600	900	900	900	900	900	1000	1000	1000	1100	1100	1200	1300	1300	1300	1400		
		430	430	438	438	445	455	465	488	500	515	553	600	625	655	690		
457.0/630	2000	1000	1000	1000	1000	1000	1000	1000	1100	1100	1100	1200	1300	1300	1300	1400	1500	
		470	470	478	478	485	495	505	528	540	555	593	640	665	695	730	770	
508.0/710	2000	1000	1000	1000	1000	1000	1000	1100	1100	1100	1200	1200	1300	1300	1400	1400	1500	1500
		515	515	235	523	530	540	550	573	585	600	638	685	710	740	775	815	860

T-piece dimensions. Series 2

Main pipe		Branch pipe d2, series 1																
		26.9	33.7	42.4	48.3	60.3	76.1	88.9	114.3	139.7	168.3	219.1	273.0	323.9	355.6	406.4	457.0	508.0
DN/D1	L1, mm	Length L2, mm																
		C- C, mm																
26.9/110	1000	700																
		170																
33.7/110	1000	700	700															
		170	170															
42.4/125	1000	700	700	700														
		178	178	185														
48.3/125	1000	700	700	700	700													
		178	178	185	185													
60.3/140	1200	700	700	700	700	700												
		185	185	193	193	200												
76.1/160	1200	700	700	700	700	700	700											
		195	195	203	203	210	220											
88.9/180	1200	700	700	700	700	700	700	700										
		205	205	213	213	220	230	240										
114.3/225	1200	700	700	700	700	700	800	800	800									
		228	228	235	235	243	253	263	285									
139.7/250	1200	700	700	700	700	800	800	800	800	900								
		240	240	248	248	255	265	275	298	310								
168.3/280	1200	800	800	800	800	800	800	800	900	900	900							
		255	255	263	263	270	280	290	313	325	340							
219.1/355	1500	800	800	800	800	800	800	800	900	900	900	1000						
		293	293	300	300	308	318	328	350	363	378	415						
273.0/450	1500	800	800	800	800	900	900	900	900	1000	1000	1100	1200					
		340	340	348	348	355	365	375	398	410	425	463	510					
323.9/500	1500	900	900	900	900	900	900	900	1000	1000	1000	1100	1200	1200				
		365	365	373	373	380	390	400	423	435	450	488	535	560				
355.6/560	1500	900	900	900	900	900	900	900	1000	1000	1000	1100	1200	1200	1300			
		395	395	403	403	410	420	430	453	465	480	518	565	590	620			
406.4/630	1600	900	900	900	900	900	1000	1000	1000	1100	1100	1200	1300	1300	1300	1400		
		430	430	438	438	445	455	465	488	500	515	553	600	625	655	690		
457.0/710	2000	1000	1000	1000	1000	1000	1000	1000	1100	1100	1100	1200	1300	1300	1300	1400	1500	
		470	470	478	478	485	495	505	528	540	555	593	640	665	695	730	770	
508.0/800	2000	1000	1000	1000	1000	1000	1000	1100	1100	1100	1200	1200	1300	1300	1400	1400	1500	1500
		515	515	235	523	530	540	550	573	585	600	638	685	710	740	775	815	860

T-piece dimensions. Series 3

Main pipe		Branch pipe d2, series 1																
		26.9	33.7	42.4	48.3	60.3	76.1	88.9	114.3	139.7	168.3	219.1	273.0	323.9	355.6	406.4	457.0	508.0
DN/D1	L1, mm	Length L2, mm																
		C- C, mm																
26.9/125	1000	700																
		190																
33.7/125	1000	700	700															
		190	190															
42.4/140	1000	700	700	700														
		198	198	205														
48.3/140	1000	700	700	700	700													
		198	198	205	205													
60.3/160	1200	700	700	700	700	700												
		208	208	215	215	225												
76.1/180	1200	700	700	700	700	700	700											
		218	218	225	225	235	245											
88.9/200	1200	700	700	700	700	700	800	800										
		228	228	235	235	245	255	265										
114.3/250	1200	800	800	800	800	800	800	800	900									
		253	253	260	260	270	280	290	315									
139.7/280	1200	800	800	800	800	800	800	800	900	900								
		268	268	275	275	285	295	305	330	345								
168.3/315	1200	800	800	800	800	800	800	800	900	900	900							
		285	285	293	293	303	313	323	348	363	380							
219.1/400	1500	800	800	800	800	800	900	900	900	1000	1000	1100						
		328	328	335	335	345	355	365	390	405	423	465						
273.0/500	1500	900	900	900	900	900	900	900	1000	1000	1000	1100	1200					
		378	378	385	385	395	405	415	4400	4500	473	515	565					
323.9/560	1500	900	900	900	900	900	900	900	1000	1000	1100	1200	1300	1300				
		408	408	415	415	425	435	445	470	485	503	545	595	625				
355.6/630	1500	900	900	1000	1000	1000	1000	1000	1100	1100	1100	1200	1300	1300	1400			
		443	443	450	450	460	470	480	505	520	538	570	630	660	695			
406.4/710	1600	1000	1000	1000	1000	1000	1000	1000	1100	1100	1100	1200	1300	1300	1400	1400		
		483	483	490	490	500	510	520	545	560	578	620	670	700	735	775		
457.0/800	2000	1000	1000	1000	1000	1000	1100	1100	1100	1200	1200	1300	1400	1400	1400	1500	1500	
		528	528	535	535	545	555	565	590	605	623	665	715	745	780	820	865	
508.0/900	2000	1100	1100	1100	1100	1100	1100	1100	1200	1200	1200	1300	1400	1400	1500	1500	1600	1700
		578	578	585	585	595	605	615	640	655	673	715	765	795	830	870	915	965

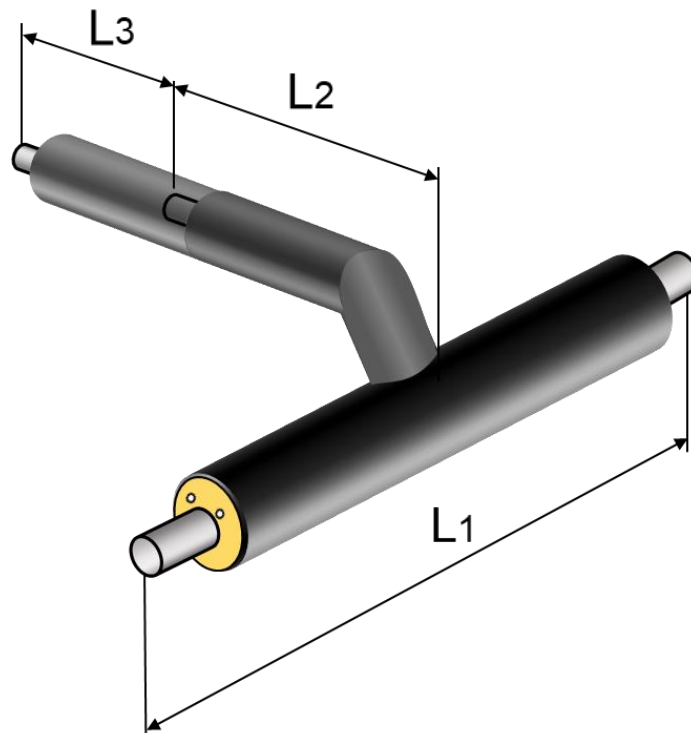

Series 1, 2, 3 and 4

Main pipe DN	For L1 and L2 see page 3.3.1.	L3 [mm] Series 1 and 2	L3 [mm] Series 3 and 4
25 – 50		330	530
65 – 80		370	570
100 – 125		500	600
150		530	630
200		600	700
250		700	800
300		750	860
350		850	930
400		930	1000
500		1000	1100
600		1100	1200
700		1200	1300
800		1300	1400
900		1400	1500
1000		1500	1600

Preinsulated perpendicular T-branches with reducer 3.3.3.

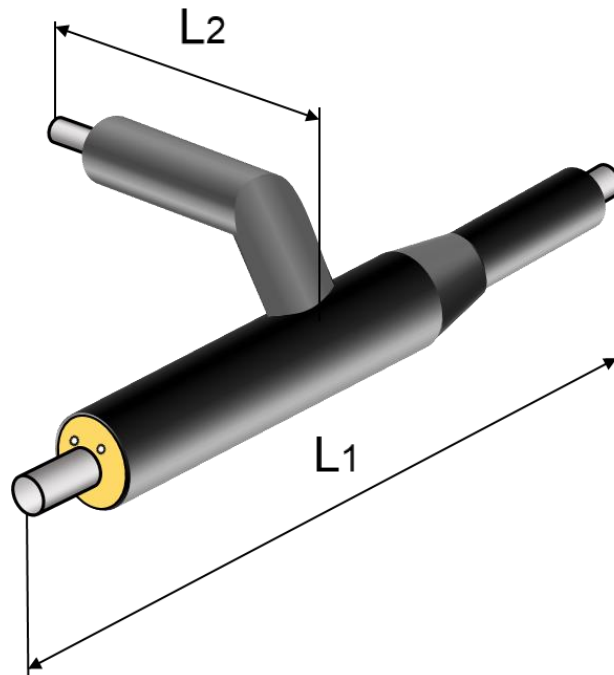

Series 1, 2, 3 and 4

Main pipe DN	Branch pipe DN	L1 [mm]	L2 [mm]
25 – 200	20 – 80	1200	1000
100 – 200	100 – 200	1500	1000
250 – 1000	25 – 80	1200	1200
250 – 1000	100 – 200	1500	1200
250 – 1000	250 – 400	1800	1500
600 – 1000	500 – 1000	2100	2100

Pipe reducer can be ordered with reduction between 1-3 dimension levels.

Diameter of branch **L2** cannot be greater than the diameter of main pipe.

On request T-pieces can be produced with any angle of branch pipe to the main pipe.

When ordering it is mandatory to inform of T-piece preference: right or left. On the drawing the T-piece is shown with left transition.

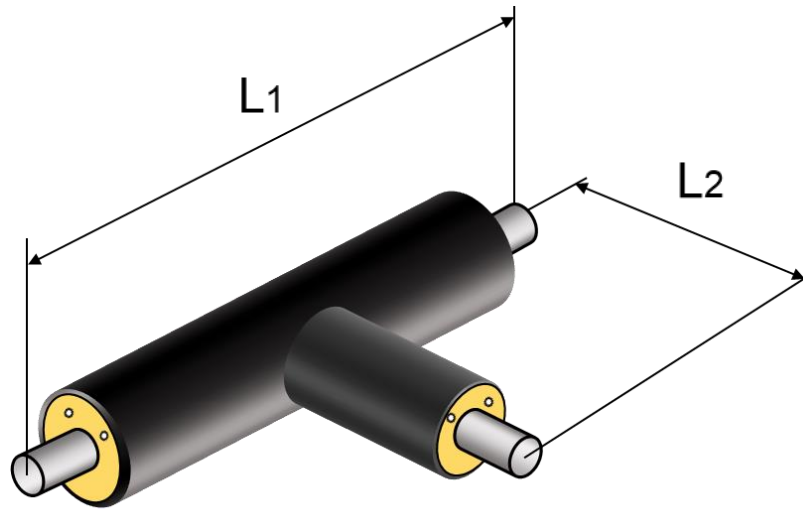

Series 1, 2, 3 and 4

Main pipe DN	Branch pipe DN	L1 [mm]	L2 [mm]
25 – 200	20 – 100	1200	700
125 – 200	125 – 200	1500	700
250 – 500	25 – 200	1500	900
250 – 500	250 – 400	1800	900
600 – 1000	25 – 500	1800	1100
600 – 1000	600 – 900	2100	1100

Diameter of branch L1 cannot be greater than diameter of main pipe L2.

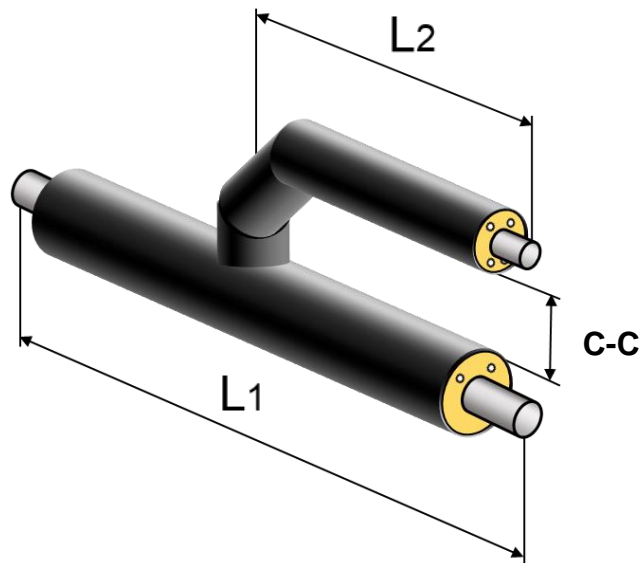

Series 1, 2, 3 and 4

Main pipe DN	Branch pipe DN	L1 [mm]
25 – 1000	20 – 100	1200
100 – 1000	125 – 200	1500
250 – 1000	250 – 400	1800
450 – 1000	450 – 500	2400
700 – 1000	600 – 700	3000

$$L2 = 0.5 * L1$$

Upon the request following parallel T-pieces can be made:

- with a custom angle of branch pipe to the main pipe.

T-piece dimensions. Series 1

Main pipe		Branch pipe d2, series 1																
		26.9	33.7	42.4	48.3	60.3	76.1	88.9	114.3	139.7	168.3	219.1	273.0	323.9	355.6	406.4	457.0	508.0
DN/D1	L1,	Length L2, mm																
	mm	550	550	550	550	600	600	650	700	700	700	800	800	850	900	1000	1050	1100
		C- C, mm																
26.6/90	1000	270																
33.7/90	1000	270	270															
42.4/110	1000	278	278	285														
48.3/110	1000	278	278	285	285													
60.3/125	1200	285	285	293	293	300												
76.1/140	1200	295	295	303	303	310	320											
88.9/160	1200	305	305	313	313	320	330	340										
114.3/200	1200	328	328	335	335	343	353	363	406									
139.7/225	1200	340	340	348	347	355	365	375	403	413								
168.3/250	1200	355	355	363	363	370	380	390	415	426	489							
219.1/315	1500	393	393	400	400	408	418	428	450	463	499	626						
273.0/400	1500	440	440	448	447	455	465	475	498	510	545	627	647					
323.9/450	1500	465	465	473	473	480	490	500	523	535	570	653	635	711				
355.6/500	1500	495	495	503	503	510	520	530	560	565	601	697	665	728	852			
406.4/560	1600	530	530	538	538	545	555	565	588	600	636	722	700	753	842	985		
457.0/630	2000	570	570	578	578	585	595	605	628	640	676	757	740	793	872	977	1109	
508.0/710	2000	605	605	613	613	630	640	650	673	685	721	802	785	838	912	1022	1094	1233

T-piece dimensions. Series 2

Main pipe		Branch pipe d2, series 1																
		26.9	33.7	42.4	48.3	60.3	76.1	88.9	114.3	139.7	168.3	219.1	273.0	323.9	355.6	406.4	457.0	508.0
DN/D1	L1,	Length L2, mm																
	mm	550	550	550	550	600	600	650	700	700	700	800	800	850	900	1000	1050	1100
		C- C, mm																
26.6/90	1000	270																
33.7/90	1000	270	270															
42.4/110	1000	278	278	285														
48.3/110	1000	278	278	285	285													
60.3/125	1200	285	285	293	293	300												
76.1/140	1200	295	295	303	303	310	320											
88.9/160	1200	305	305	313	313	320	330	340										
114.3/200	1200	328	328	335	335	343	353	363	406									
139.7/225	1200	340	340	348	347	355	365	375	403	413								
168.3/250	1200	355	355	363	363	370	380	390	415	426	489							
219.1/315	1500	393	393	400	400	408	418	428	450	463	499	626						
273.0/400	1500	440	440	448	447	455	465	475	498	510	545	627	647					
323.9/450	1500	465	465	473	473	480	490	500	523	535	570	653	635	711				
355.6/500	1500	495	495	503	503	510	520	530	560	565	601	697	665	728	852			
406.4/560	1600	530	530	538	538	545	555	565	588	600	636	722	700	753	842	985		
457.0/630	2000	570	570	578	578	585	595	605	628	640	676	757	740	793	872	977	1109	
508.0/710	2000	605	605	613	613	630	640	650	673	685	721	802	785	838	912	1022	1094	1233

T-piece dimensions. Series 3

Main pipe		Branch pipe d2, series 1																
		26.9	33.7	42.4	48.3	60.3	76.1	88.9	114.3	139.7	168.3	219.1	273.0	323.9	355.6	406.4	457.0	508.0
DN/D1	L1,	Length L2, mm																
	mm	C- C, mm																
26.6/90	1000	285																
33.7/90	1000	285	285															
42.4/110	1000	293	293	300														
48.3/110	1000	293	293	300	300													
60.3/125	1200	303	303	311	311	320												
76.1/140	1200	312	312	320	321	330	340											
88.9/160	1200	322	322	331	330	340	350	360										
114.3/200	1200	348	348	355	355	366	376	386	415									
139.7/225	1200	363	363	371	370	380	390	400	430	440								
168.3/250	1200	380	380	388	388	398	408	418	447	458	489							
219.1/315	1500	423	423	430	430	441	451	461	490	501	529	627						
273.0/400	1500	473	473	480	480	490	500	510	540	550	579	677	660					
323.9/450	1500	503	503	511	510	520	530	540	570	580	609	707	690	751				
355.6/500	1500	538	538	546	546	555	565	575	605	615	644	742	725	792	882			
406.4/560	1600	578	578	586	586	595	605	615	645	655	686	782	765	832	910	995		
457.0/630	2000	623	623	630	630	640	650	660	690	700	729	827	810	877	955	1027	1119	
508.0/710	2000	673	673	680	680	690	700	710	740	750	779	877	860	927	1005	1077	1149	1263

T-branches with air vent/drain unit

3.3.6.

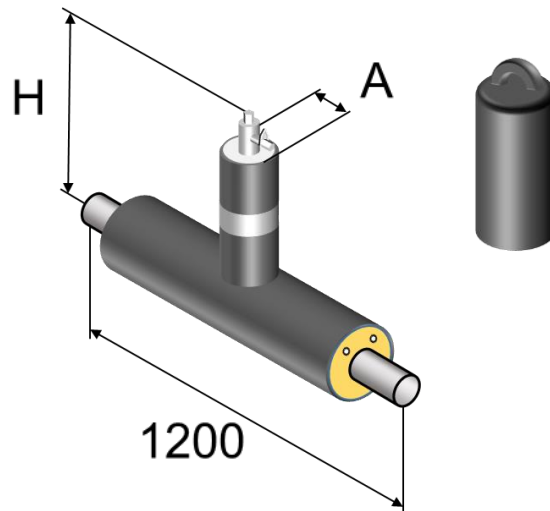

Series 1, 2, 3 and 4

Main pipe DN	H [mm]	Air vent/drain DN	A [mm]
25	409	25	125
32	414	40	125
40	417	50	140
50	423	65	160
65	431		
80	438		
100	450		
125	463		
150	477		
200	502		
250	530		
300	554		
350	570		
400	596		
500	650		
600	700		
700	758		
800	800		
900	850		

Used for air release or water drainage. Tower construction in stainless steel.

The end cap shall not lie continuously under water. Backfilling may not reach the end cap, alarm wire or marking tape. It is possible to order a custom height H.

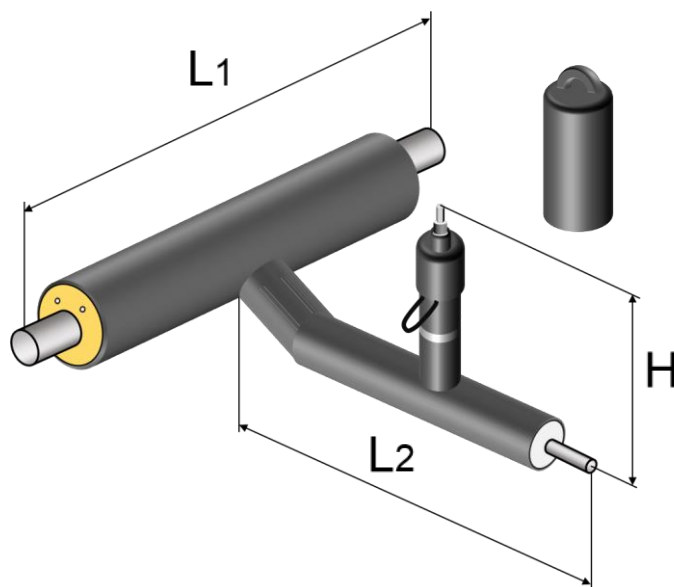

Series 1, 2, 3 and 4

Main pipe DN	Branch pipe DN	L1 [mm]	L2 [mm]
25 – 80	25 – 40	1000	1500
100 – 150	50 – 80	1200	1500
200 – 300	100	1400	2000
350 – 450	125	1600	2200

It is possible to order different diameter of valve **L2**, height **H** and branch length **L1**. Service valve produced in stainless steel. **H** standard length according 3.4.1.

Ball valve made of stainless steel, X5CrNi18-10 (1.4301).

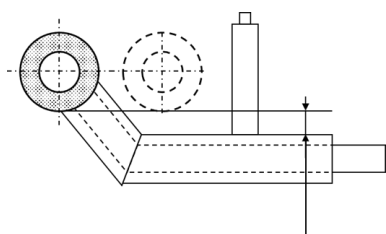

h=50 mm

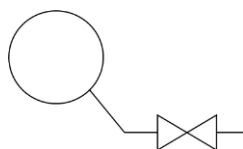

Draining

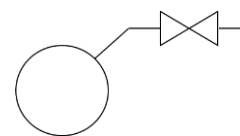

Venting

Preinsulated valve

3.4.1.

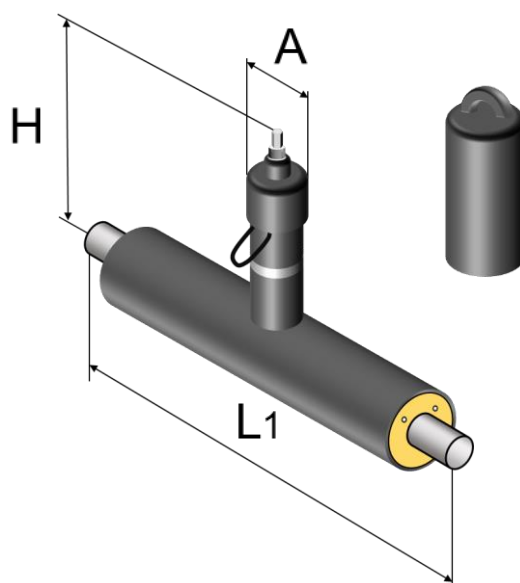

Series 1, 2, 3 and 4

Main pipe DN	L1 [mm]	H [mm]	A [mm]	Wrench size [mm]
25	1500	382	110	19
32	1500	388	110	19
40	1500	401	110	19
50	1500	406	110	19
65	1500	415	110	19
80	1500	426	110	19
100	1500	450	125	27
125	1500	455	125	27
150	1500	475	125	27
200	1500	517	160	50
250	1500	560	160	50
300	1800	610	160	50
350	1800	906	350	
400	2000	977	350	
500	custom	1056	350	
600	custom	1183	350	

The construction of ball valve control axis provides possibility to open and close the valve from above-ground using T-shaped end key.

Valves DN300 and greater provided with gear or hydrox actuator.

It is possible to order a custom height of the valve **H**.

Valves with one (1) air vent/drain unit

3.4.2.

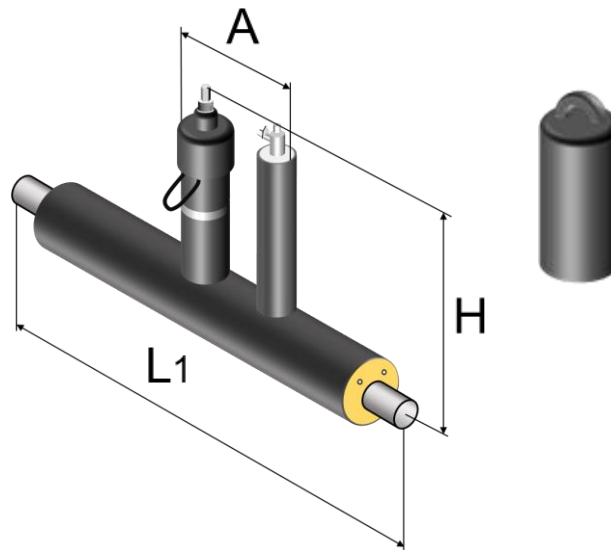

Series 1, 2, 3 and 4

Main pipe DN	L1 [mm]	H [mm]	A [mm]	Wrench size [mm]
25	1500	382	360	19
32	1500	388	360	19
40	1500	401	360	19
50	1500	406	360	19
65	1500	415	360	19
80	1500	426	360	19
100	1500	450	368	27
125	1500	455	368	27
150	1500	475	368	27
200	1500	517	385	50
250	1500	560	460	50
300	1800	610	485	50
350	1800	906	583	
400	2000	977	683	
500	2200	1056	783	
600	2400	1183	873	

Tower construction in stainless steel. The construction of ball valve control axis provides possibility to open and close the valve from above-ground using T-shaped end key. Valves DN300 and greater provided with gear or hydrox actuator. It is possible to order a custom height of the valve **H**.

Valves with two (2) air vent/drain units

3.4.3.

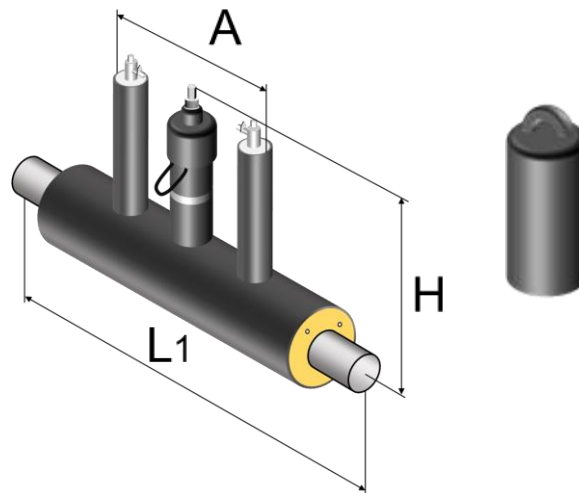

Series 1, 2, 3 and 4

Main pipe DN	L1 [mm]	H [mm]	A [mm]	Wrench size [mm]
25	1500	382	610	19
32	1500	388	610	19
40	1500	401	610	19
50	1500	406	610	19
65	1500	415	610	19
80	1500	426	610	19
100	1500	450	610	27
125	1500	455	610	27
150	1500	475	610	27
200	1500	517	610	50
250	1500	560	810	50
300	1800	610	810	50
350	1800	906	810	
400	2000	977	1010	
500	2200	1056	1210	
600	2400	1183	1310	

Tower construction in stainless steel. The construction of ball valve control axis provides possibility to open and close the valve from above-ground using T-shaped end key.

Valves DN300 and greater provided with gear or hydrox actuator.

Same valve set or same nominal diameter units that are not shown in the table are available upon the request. It is possible to order a custom height of the valve **H**.

Valve unit with two (2) air vent/drain units

3.4.4.

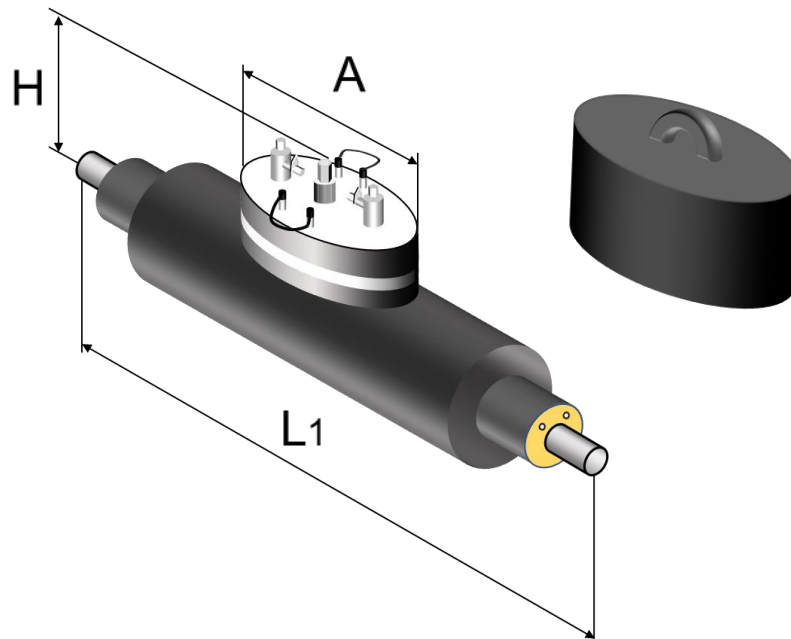

Series 1, 2, 3 and 4

Main pipe DN	L1 [mm]	H [mm]	A [mm]	Wrench size [mm]	Air vent/drain DN
25	1500	382	235	19	25
32	1500	388	235	19	40
40	1500	401	235	19	50
50	1500	406	235	19	65
65	1500	415	295	19	
80	1500	426	295	19	
100	1500	450	295	27	
125	1500	455	340	27	
150	1500	475	415	27	
200	1500	517	415	50	
250	1500	560	415	50	
300	1800	610	415	50	
350	1800	906			
400	2000	977			
500	2200	1056			
600	2400	1183			

Tower construction in stainless steel.

Valves DN300 and greater provided with gear or hydrox actuator.

Preinsulated combination valve - Standard design

3.4.5.

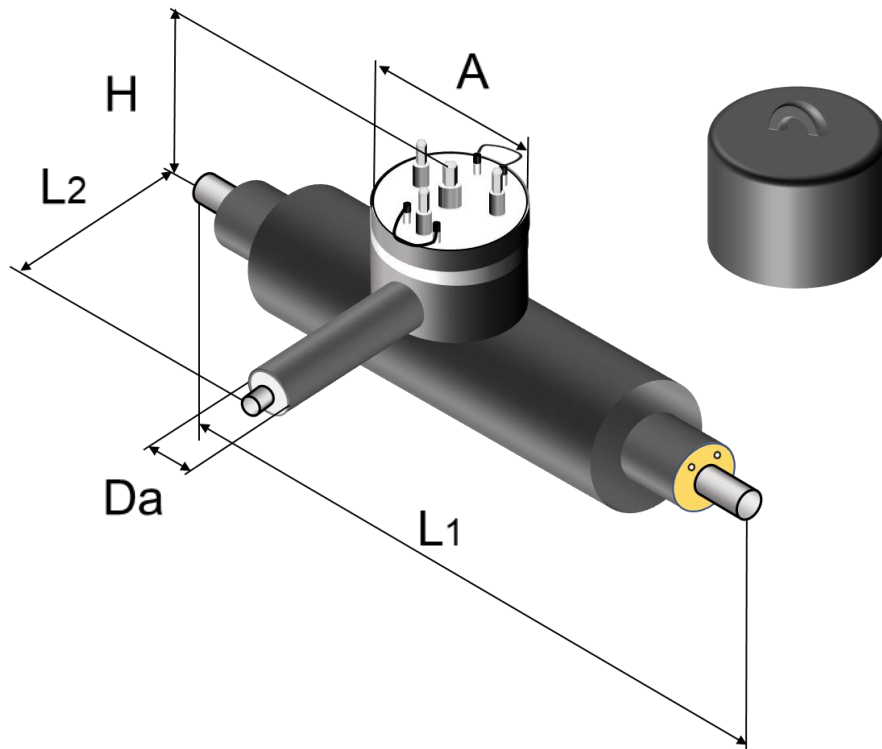

Series 1, 2, 3 and 4

Main pipe DN	L1 [mm]	L2 [mm]	H [mm]	A [mm]	Wrench size [mm]	Da [mm]
100	1800	650	500	415	27	140
125	1800	650	500	415	27	140
150	1800	700	530	415	27	140
200	1800	700	560	415	50	140
250	1800	700	600	450	50	140
300	2100	750	700	450	50	140

Drain/air release pipe and tower construction are made of stainless steel.

Valves DN300 and greater provided with gear or hydrox actuator.

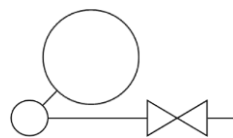
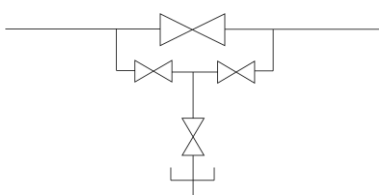

Draining

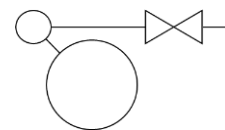

Venting

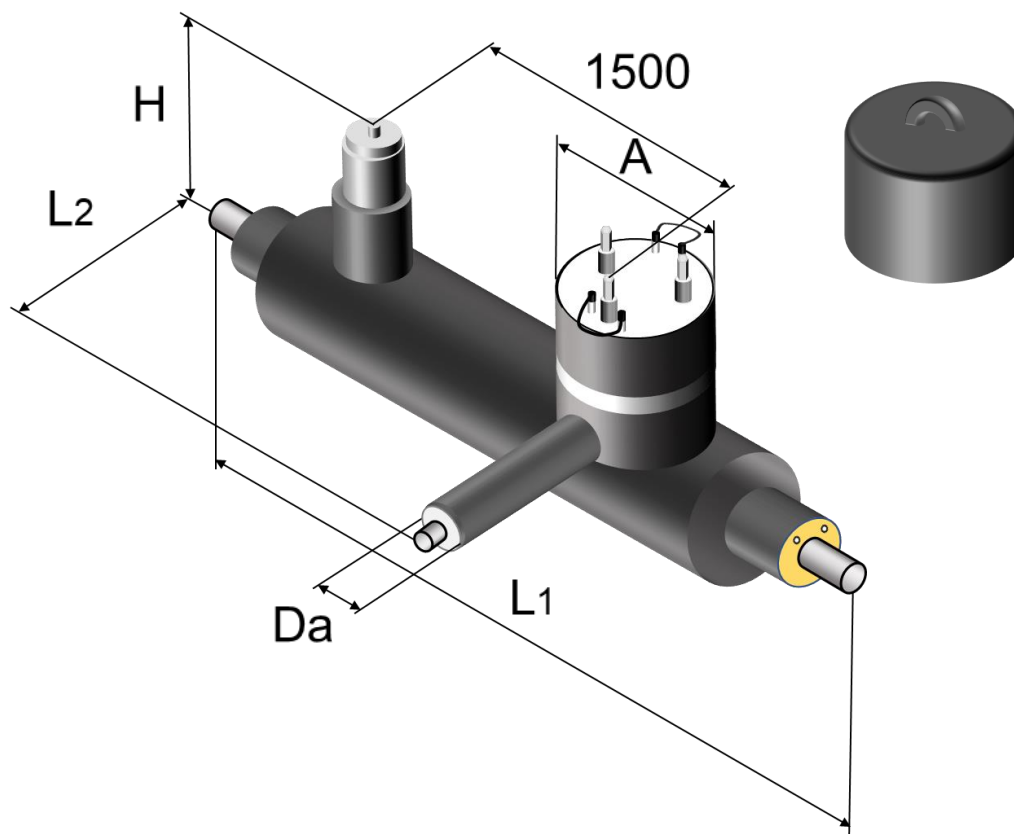

Series 1, 2, 3 and 4

Main pipe DN	L1 [mm]	L2 [mm]	H [mm]	A [mm]	Bypass valve DN	Da [mm]
350	3200	800	940	450	50	140
400	3400	800	940	450	50	140
500	3600	900	1135	450	50	140

Drain/air release pipe and tower construction are made of stainless steel.

Valves DN300 and greater provided with gear or hydrox actuator.

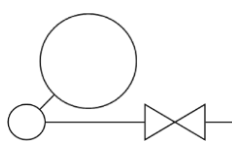
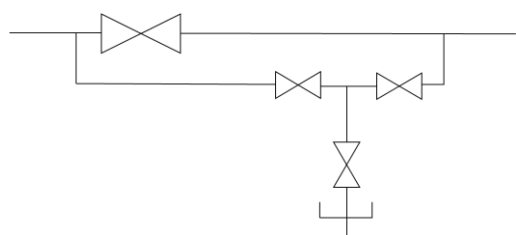

Draining

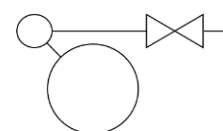

Venting

Preinsulated valve with bypass and outflow system 3.4.7.

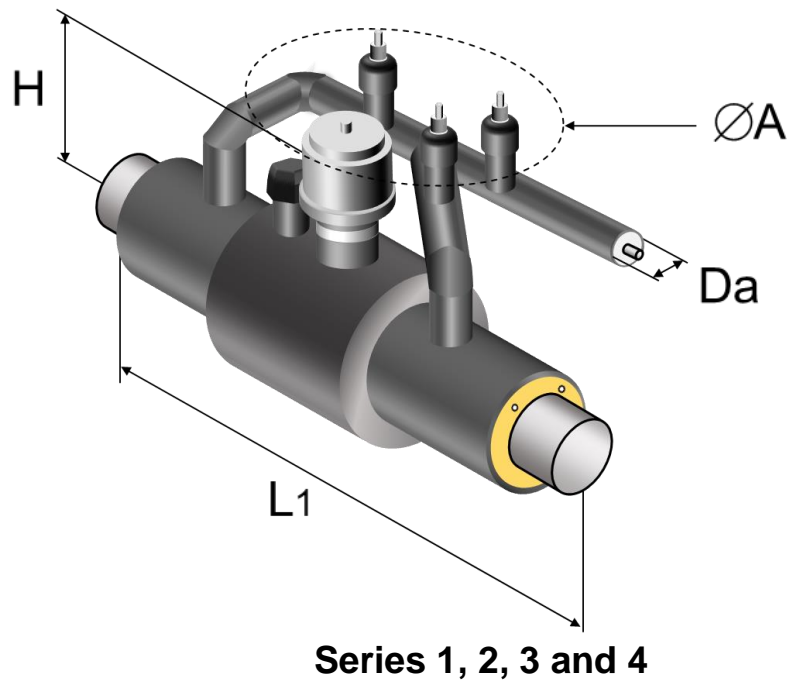

Main pipe DN	H [mm]	L1 [mm]	A [mm]	Bypass valve DN	Da [mm]
150	528	1500	600	25	125
200	535	2000	600	25	125
250	563	2000	600	25	125
300	614	2000	600	25	125
350	639	2000	800	25	125
400	691	2000	800	50	140
500	947	2500	800	50	140
600	1020	2500	800	50	140
700	1243	3000	1000	50 – 150	140 – 280

Alarm wires outtake in a screw cap.

*Upon request can be ordered different bypass DN.

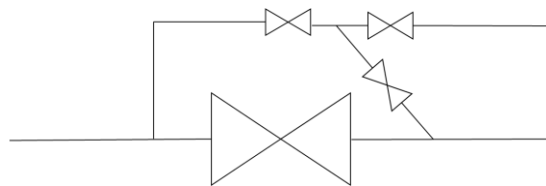

Preinsulated valve unit compact

3.4.8.

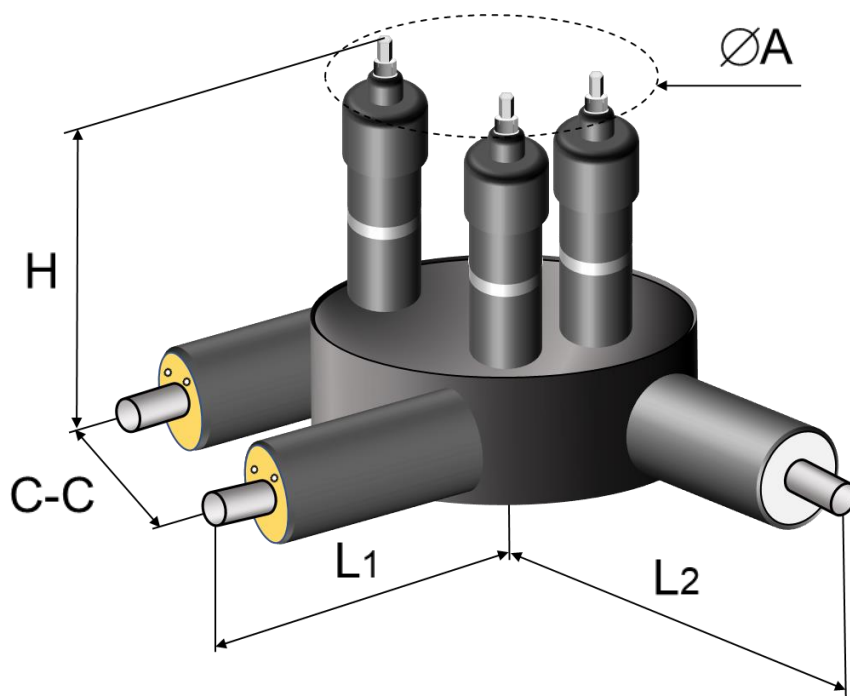

Series 1, 2, 3 and 4

Main pipe DN	C-C [mm]	H [mm]	H min [mm]	A [mm]	L1 [mm]	L2 [mm]
25	300	382	190	357	600	600
32	380	388	200	407	670	650
40	385	401	200	425	670	670
50	455	406	210	479	780	700
65	500	415	210	517	810	730
80	530	426	225	537	820	758

It is possible to order different diameter of valve, height **H**, branch lengths **L1** and **L2**.
 Drain release pipe is made of stainless steel.

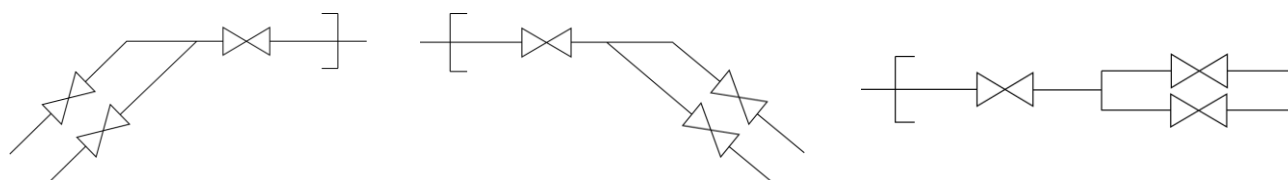

right

left

straight

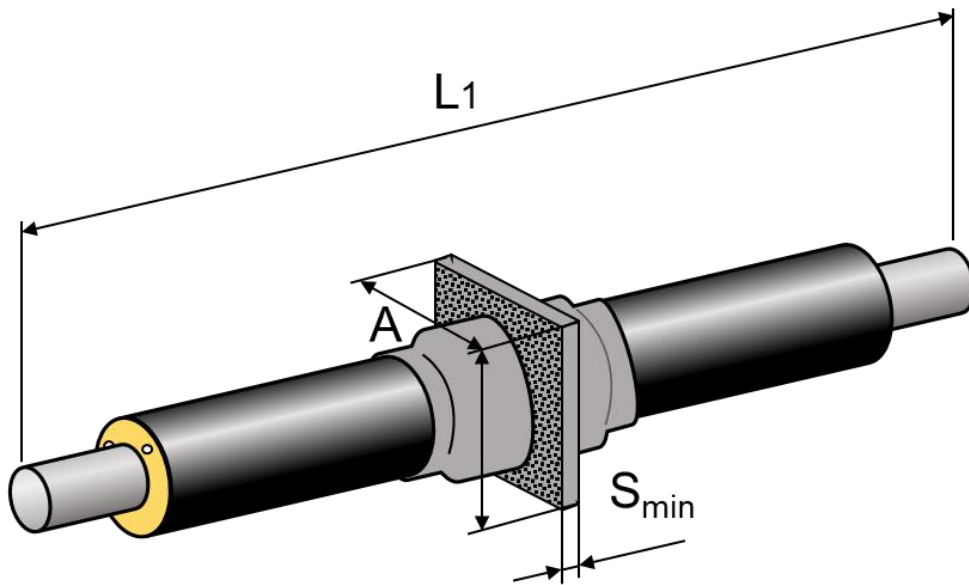

Series 1, 2, 3 and 4

Main pipe DN	Max load kN $\Delta T = 60^{\circ}C$	A [mm]	S [mm]	Pressure area [cm ²]	L1 [mm]
25	38	200	25	191	2 000
32	49	220	25	243	2 000
40	56	220	25	243	2 000
50	78	240	25	289	2 000
65	100	280	25	452	2 000
80	129	300	30	392	2 000
100	187	350	30	565	2 000
125	230	400	30	765	2 000
150	310	450	30	875	2 300
200	455	550	35	1385	2 300
250	630	650	40	1730	2 300
300	840	700	40	1885	2 300
400	1200	850	40	2560	2 500
500	1500	1000	65	4000	2 500
600	2000	1200	65	6200	3 000

Anchor plate next to working pipe is strengthened with additional steady ribs.

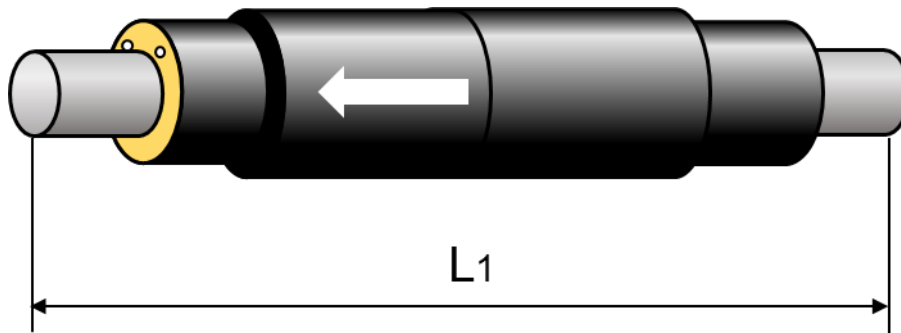

Series 1, 2, 3 and 4

Main pipe DN	Length of max compensation [mm]	L1 [mm]
40	100	2200
50	100	2200
65	100	2200
80	100	2200
100	125	2200
125	125	2200
150	125	2200
200	150	2200
250	150	2200
300	150	2200
350	150	2200
400	150	2500
450	150	2500
500	150	2800
600	150	2800

Water flow is marked with an arrow.

Axial displacement can be changed upon a request.

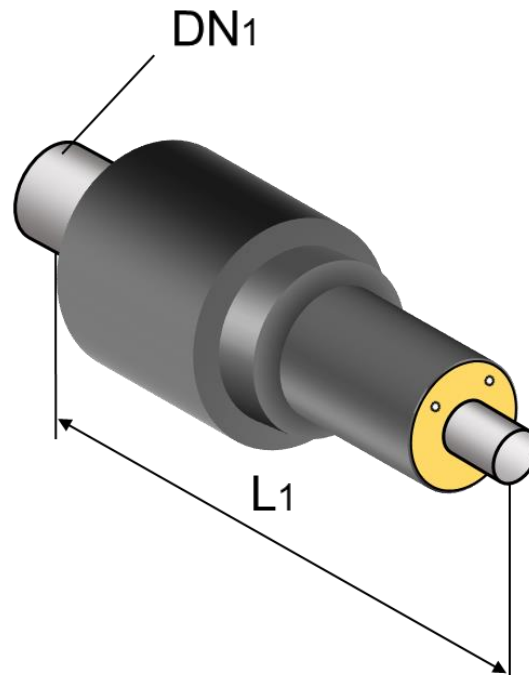

Series 1, 2, 3 and 4

Main pipe DN1	L1 [mm]
25 – 300	900
350 – 500	1100
600 – 800	1300

Can be ordered with dimensions greater than DN800 and reduction between 1 – 3 dimension levels.

On request: reducer can be produced as one product together with perpendicular or parallel T-branches.

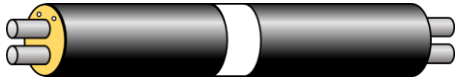

Pipes
4.1.1. – 4.1.5.

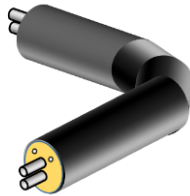

Bends
4.2.1. – 4.2.4.

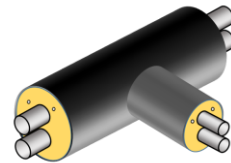

T-pieces
4.3.1. – 4.3.3.

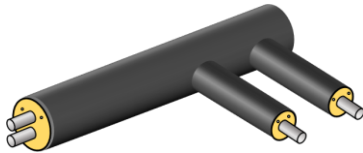

Transition pipes
4.3.4. – 4.3.5.



Valves
4.4.1.

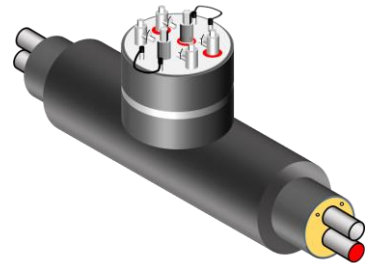

**Valves with
air vent/drain units**
4.4.2.

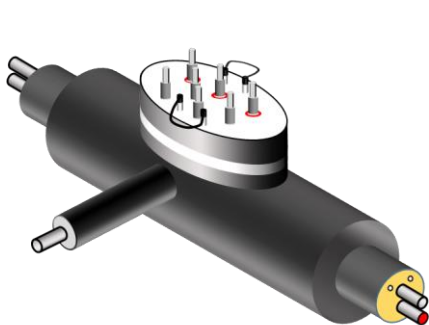

Combination valves
4.4.3. – 4.4.4.

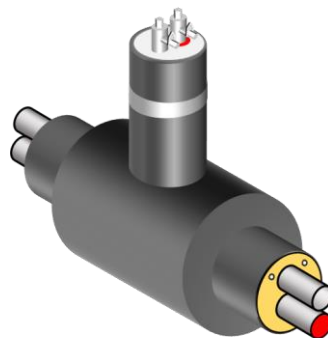

Air vent/drain units
4.4.5.

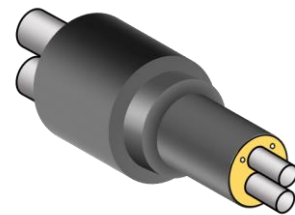

Diameter reducers
4.5.1.

Preinsulated twin pipes

4.1.1.

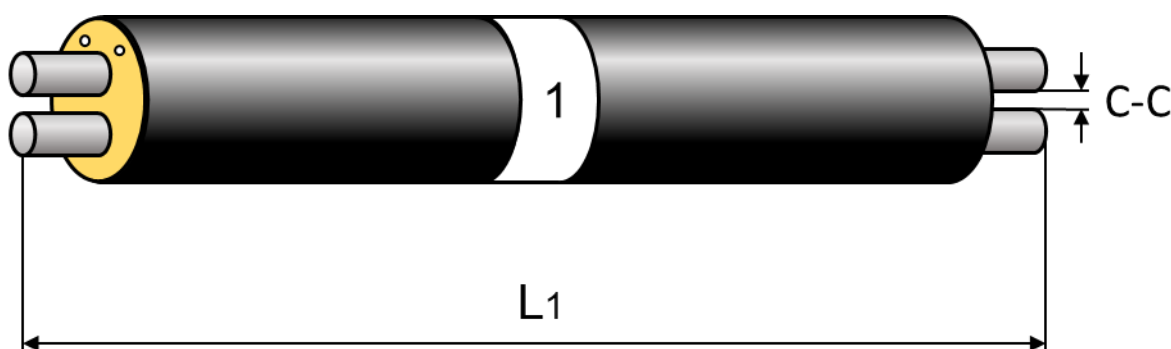

Series 1

Main pipe DN	PE casing pipe [mm]	Weight [kg/m]	C-C [mm]	Water content [l/m]	Transfer capacity $\Delta T = 50\text{ }^{\circ}\text{C}$ [kW]
20	125	4,9	19	0,8	65
25	140	7,1	19	1,2	100
32	160	9,1	19	2,2	180
40	160	9,6	19	3,0	230
50	200	13,1	20	4,6	370
65	225	16,5	20	7,0	700
80	250	20,7	25	10,6	1 000
100	315	30,7	25	18,0	1 800
125	400	41,5	30	27,6	3 300
150	450	51,0	40	40,4	5 000
200	560	76,0	45	69,4	10 000

Pipe length **L1** can be ordered 6; 12; 16; 18 m.

Material of service pipe - steel. On request - copper or stainless steel.

Material of casing pipe - high density polyethylene (PE100).

Preinsulated twin pipes

4.1.2.

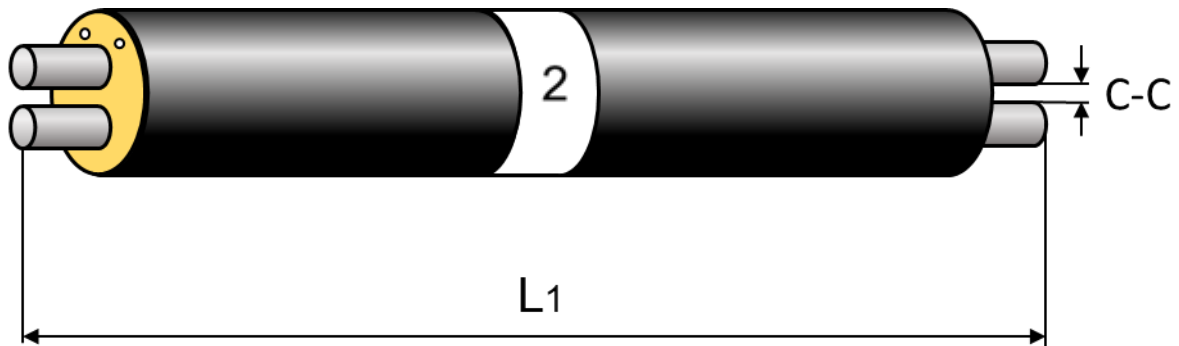

Series 2

Main pipe DN	PE casing pipe [mm]	Weight [kg/m]	C-C [mm]	Water content [l/m]	Transfer capacity $\Delta T = 50\text{ }^{\circ}\text{C}$ [kW]
20	140	6,1	19	0,8	65
25	160	7,8	19	1,2	100
32	180	9,9	19	2,2	180
40	180	10,3	19	3,0	230
50	225	14,0	20	4,6	370
65	250	17,6	20	7,0	700
80	280	22,8	25	10,6	1 000
100	355	33,9	25	18,0	1 800
125	450	46,3	30	27,6	3 300
150	500	56,5	40	40,4	5 000
200	630	82,9	45	69,4	10 000

Pipe length **L1** can be ordered 6; 12; 16; 18 m.

Material of service pipe - steel. On request - copper or stainless steel.

Material of casing pipe - high density polyethylene (PE100).

Preinsulated twin pipes

4.1.3.

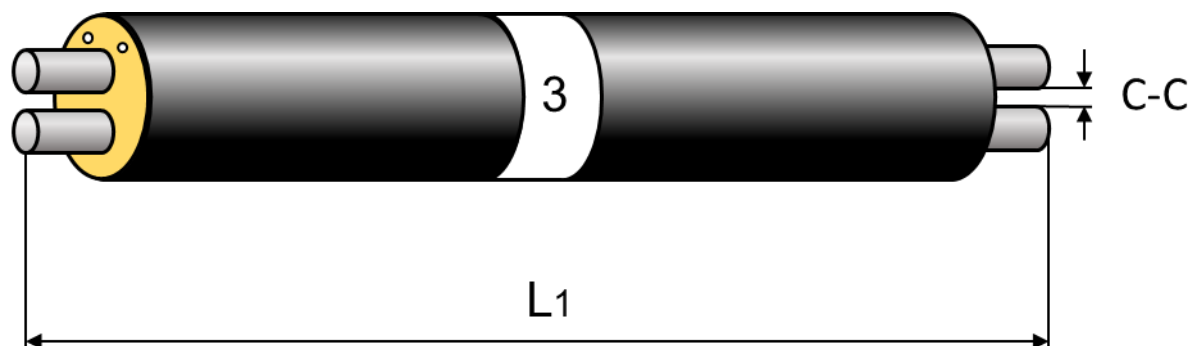

Series 3

Main pipe DN	PE casing pipe [mm]	Weight [kg/m]	C-C [mm]	Water content [l/m]	Transfer capacity $\Delta T = 50\text{ }^{\circ}\text{C}$ [kW]
20	160	6,74	19	0,8	65
25	180	8,5	19	1,2	100
32	200	10,6	19	2,2	180
40	200	11,1	19	3,0	230
50	250	15,1	20	4,6	370
65	280	19,7	20	7,0	700
80	315	24,9	25	10,6	1 000
100	400	37,8	25	18,0	1 800
125	500	51,8	30	27,6	3 300
150	560	63,7	40	40,4	5 000
200	710	91,2	45	69,4	10 000

Pipe length **L1** can be ordered 6; 12; 16; 18 m.

Material of service pipe - steel. On request - copper or stainless steel.

Material of casing pipe - high density polyethylene (PE100).

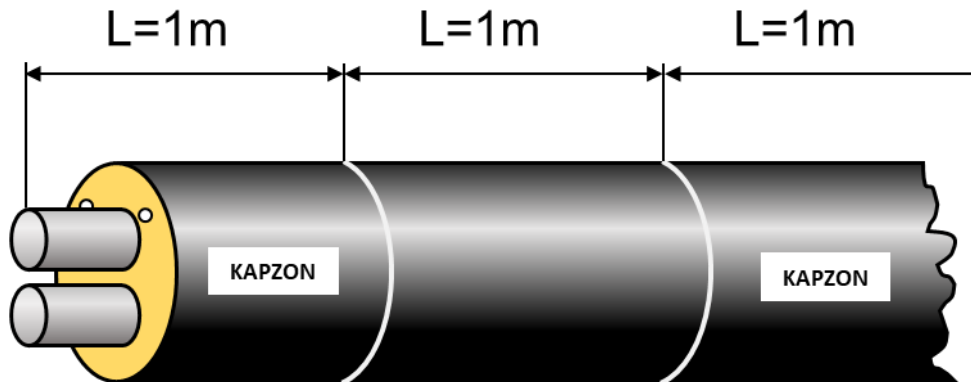

Series 1, 2 and 3

Steel service pipe is covered by a plastic foil every second meter along the entire pipe length. This arrangement allows easy removal of the foam from the steel in the sections which are indicated on the outside casing pipe. Whole lengths or parts of pipes cut-to-length can be installed at any place.

L1 segments can be ordered on 6; 12; 16; 18 m long pipes.

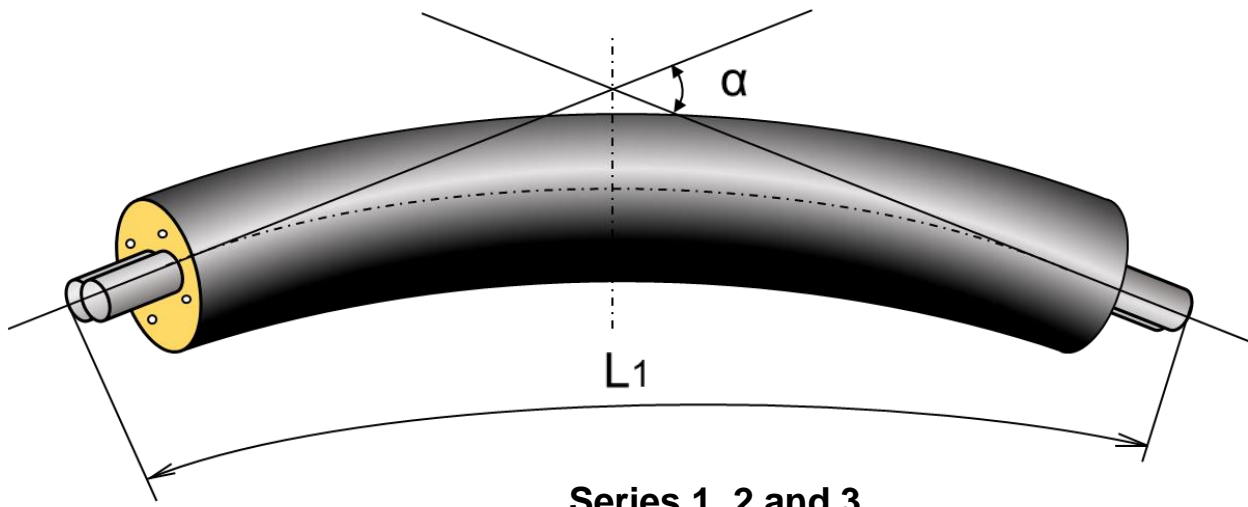

Main pipe DN	PE casing pipe [mm]	Max deflection angle on L1=12m	Max deflection angle on L1=16m
25 – 50	140 – 250	45°	45°
65 – 80	225 – 315	45°	45°
100	315 – 400	35°	35°
125 – 150	400 – 560	30°	30°
200	560 – 710	20°	20°

Allowable accuracy: DN 25 – 80 mm +/- 2°

DN 100 – 200 mm +/- 1°

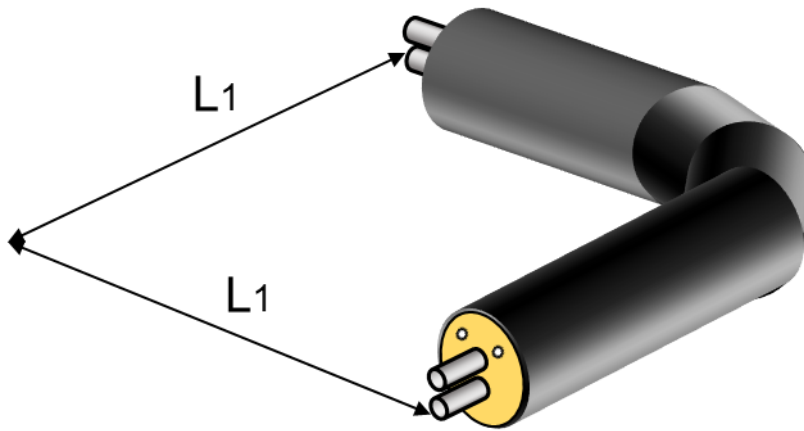

Series 1, 2 and 3

Main pipe DN	PE casing pipe [mm]			L1 [mm]
	Series 1	Series 2	Series 3	
20	125	140	160	1000
25	140	160	180	1000
32	160	180	200	1000
40	160	180	200	1000
50	200	225	250	1000
65	225	250	280	1000
80	250	280	315	1000
100	315	355	400	1000
125	400	450	500	1000
150	450	500	560	1000
200	560	630	710	1000

Angle α in a standard bends is 90° .

The bends with degrees from 5° to 90° and leg length up to 10,0 m can be made on request.

Preinsulated twin pipe vertical bends

4.2.2.

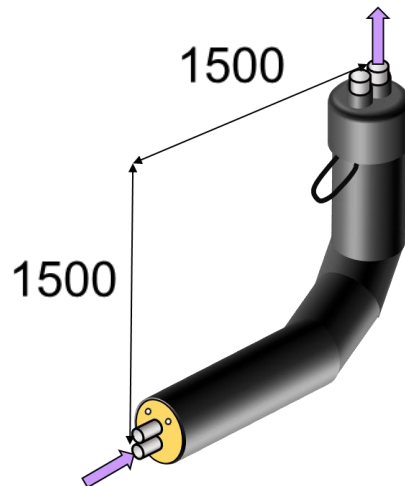

Series 1, 2 and 3

Main pipe DN	PE casing pipe [mm]		
	Series 1	Series 2	Series 3
20	125	140	160
25	140	160	180
32	160	180	200
40	160	180	200
50	200	225	250
65	225	250	280
80	250	280	315
100	315	355	400
125	400	450	500
150	450	500	560
200	560	630	710

Different leg length up to 10,0 m can be made on request.

Can be ordered without an end cap.



Optional right



Optional left

Connection bend for facade installation

4.2.3.

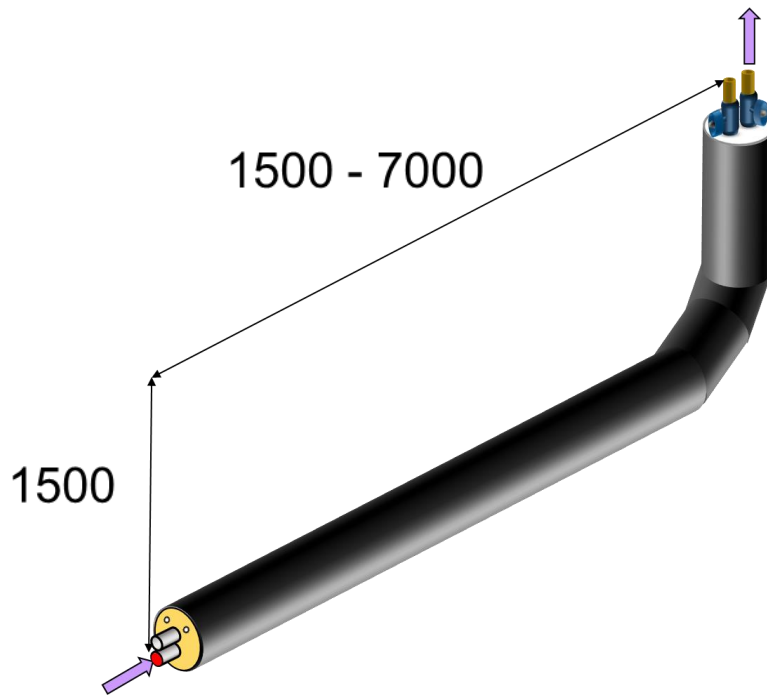

Series 1, 2 and 3

Main pipe DN	PE casing pipe [mm]
20	125 – 160
25	140 – 180

Connector bend for facade installation is supplied with extended neck valves and a copper connection pipe. Flow valve is marked in red. The connection bend can be ordered with up to 7m leg length, custom angles, dimensions and with left or right flow handle position.

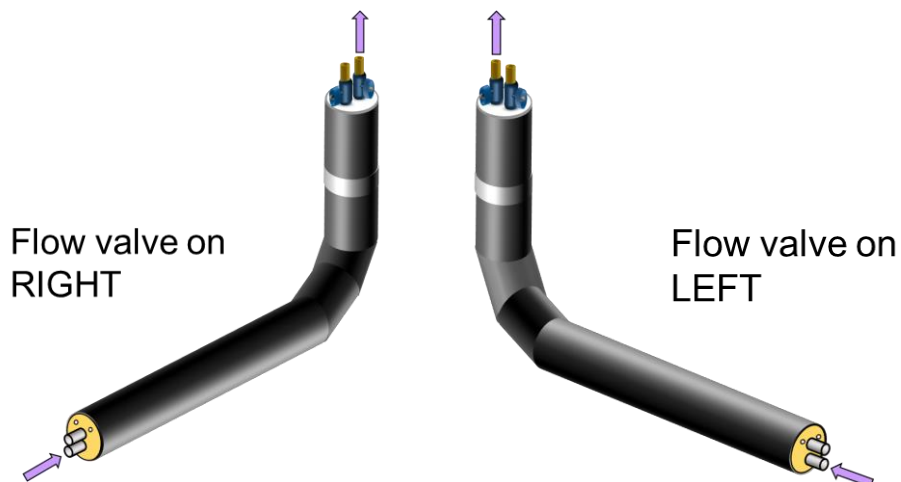

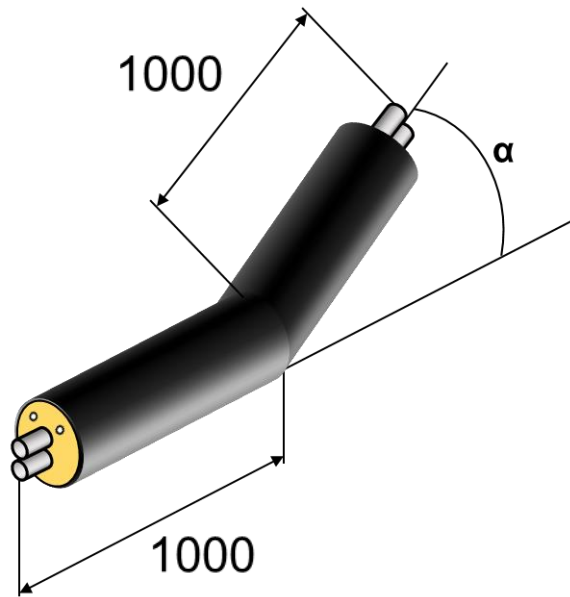

Series 1, 2 and 3

Main pipe DN	PE casing pipe [mm]		
	Series 1	Series 2	Series 3
20	125	140	160
25	140	160	180
32	160	180	200
40	160	180	200
50	200	225	250
65	225	250	280
80	250	280	315
100	315	355	400
125	400	450	500
150	450	500	560
200	560	630	710

Different leg length up to 10,0 m can be made on request.

Can be ordered with an angle up to 90 deg.

Preinsulated twin pipe T-branches

4.3.1.

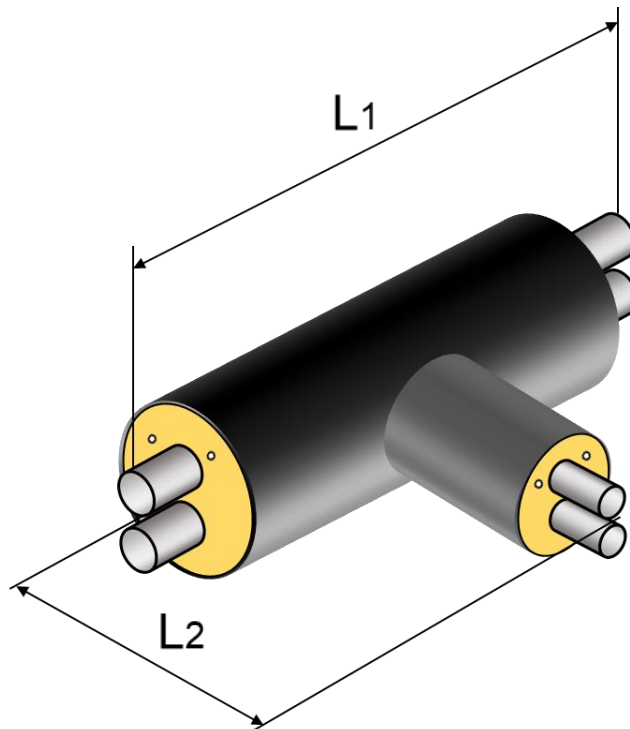

Series 1, 2 and 3

Main pipe DN	Branch pipe DN	Main pipe		PE casing pipe [mm]			
		L1 [mm]	L2 [mm]	DN	Series 1	Series 2	Series 3
25 – 200	20 – 100	1200	700	25	140	160	180
125 – 200	125 – 150	1500	900	32	160	180	200
200	200	1500	900	40	160	180	200
				50	200	225	250
				65	225	250	280
				80	250	280	315
				100	315	355	400
				125	400	450	500
				150	450	500	560
				200	560	630	710

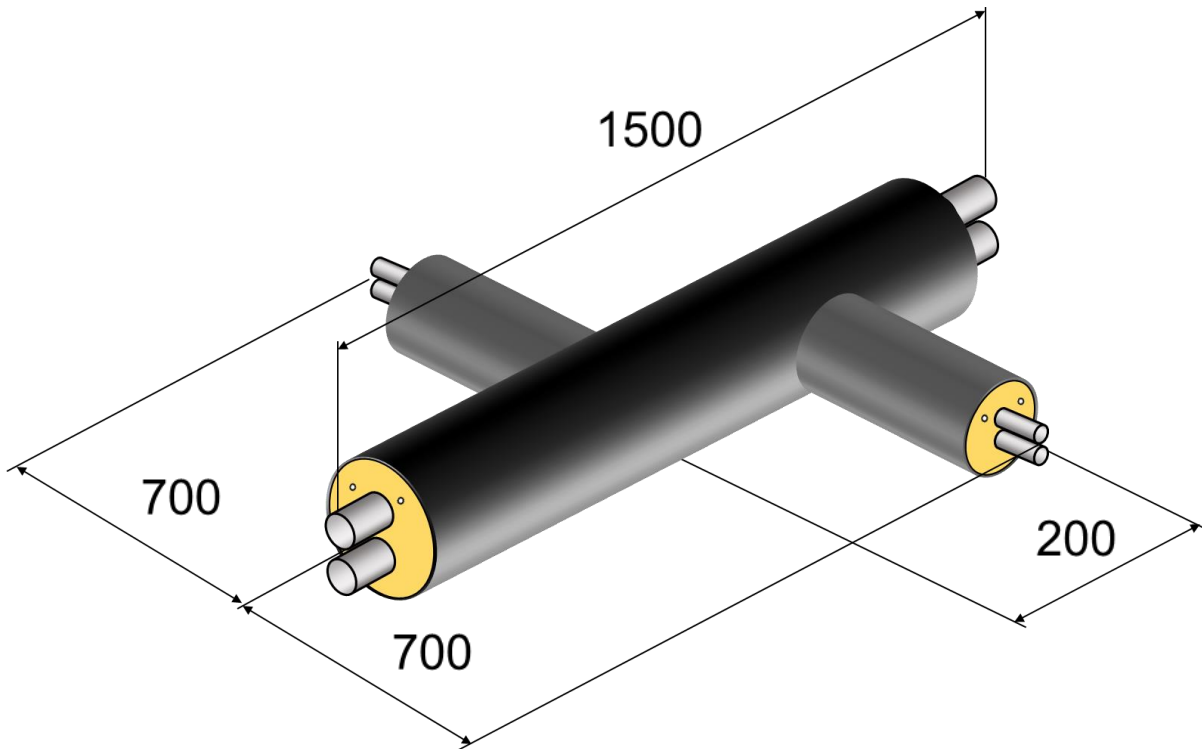

Series 1, 2 and 3

Main pipe DN	Branch pipe DN
25 - 200	20 - 65

Diameter of branch cannot be greater than diameter of main pipe.

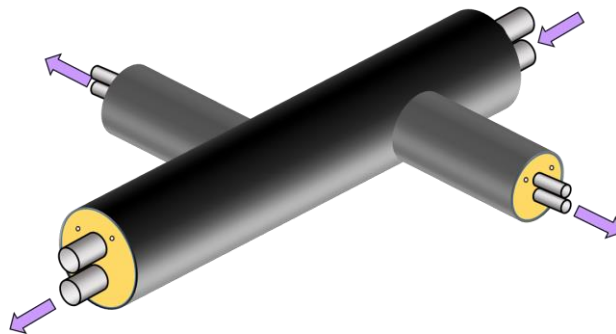

Preinsulated Twin T-piece

4.3.3.

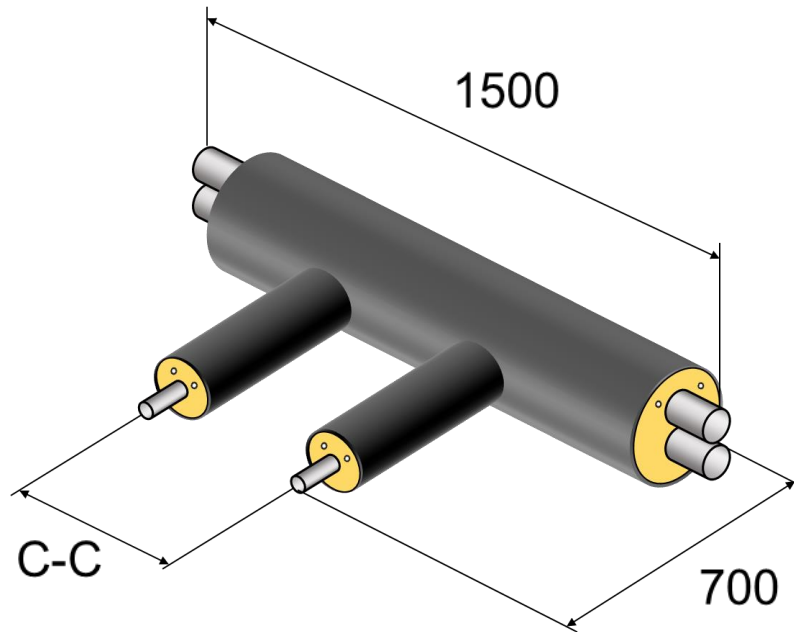

Series 1, 2 and 3

Main pipe DN	Branch pipe DN	C-C [mm]
25 - 200	20	310
	25	310
	32	325
	40	325
	50	340
	65	360
	80	380

Branch pipe is insulated in series 2.

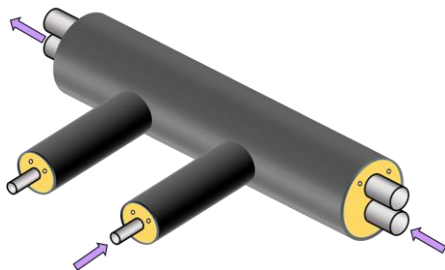

Right

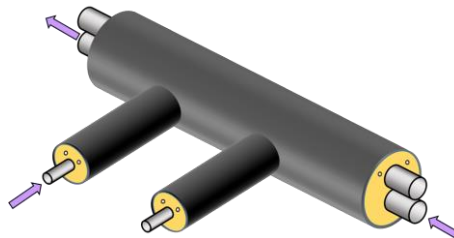

Left

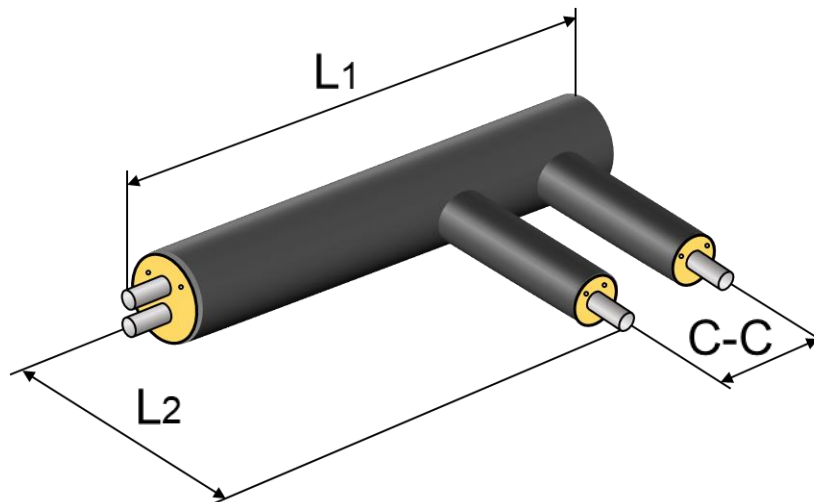

Series 1, 2 and 3

Main pipe DN	C-C [mm]	L1 [mm]	L2 [mm]
25	265	1586	1000
32	280	1593	1000
40	280	1610	1000
50	305	1630	1000
65	330	1603	700
80	360	1620	700
100	435	1740	700
125	530	1780	700
150	580	1835	700
200	710	2015	900

Two (2) different transformation types are possible:

- left hand flow with flowpipe under;
- right hand flow with flowpipe under (flowpipe is marked in dark color).

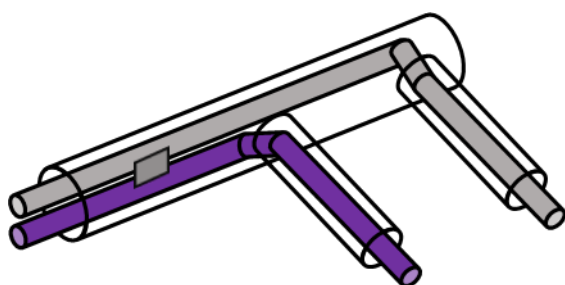

Left hand flow

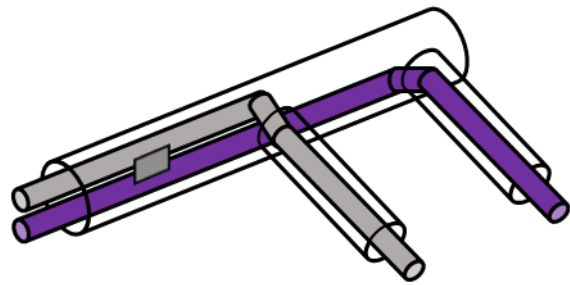

Right hand flow

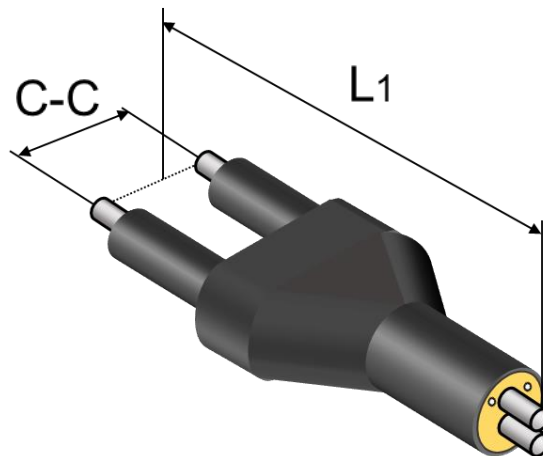

Series 1, 2 and 3

Main pipe DN	C-C [mm]	L1 [mm]
25	265	1973
32	280	1971
40	280	1971
50	305	1966
65	330	1962
80	360	1955
100	435	1955
125	530	2500
150	580	2500
200	710	2500

Two (2) different transformation executions are possible:

- from two pipe system to double pipe system;
- from double pipe system to two pipe system.

Can order pipes with left hand flow and right-hand flow. Flow pipe is at the bottom in double pipe in both executions. Flow pipe is marked in dark color.

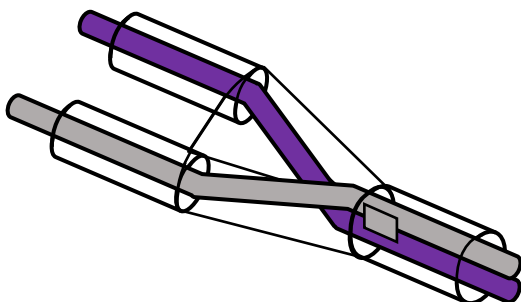

Left hand flow

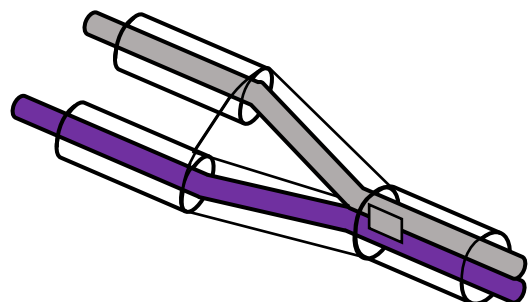

Right hand flow

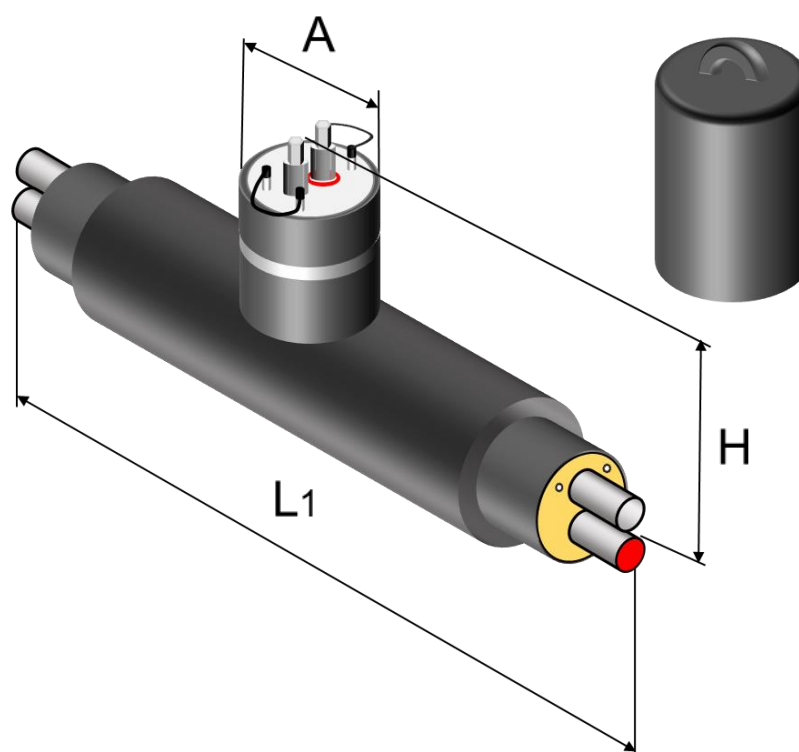

Series 1, 2 and 3

Main pipe DN	L1 [mm]	H [mm]	A [mm]	Wrench size [mm]
25	1800	409	150	19
32	1800	422	170	19
40	1800	435	170	19
50	1800	451	190	19
65	1800	463	190	19
80	2600	483	190	19
100	2800	519	235	27
125	3200	540	295	27
150	3400	578	295	27
200	3600	652	295	50

The construction of ball valve control axis provides possibility to open and close the valve from above-ground using T-shaped end key.

It is possible to order different height of the valve **H**.

Tower construction in stainless steel.

Preinsulated twin valves with air vent/drain units

4.4.2.

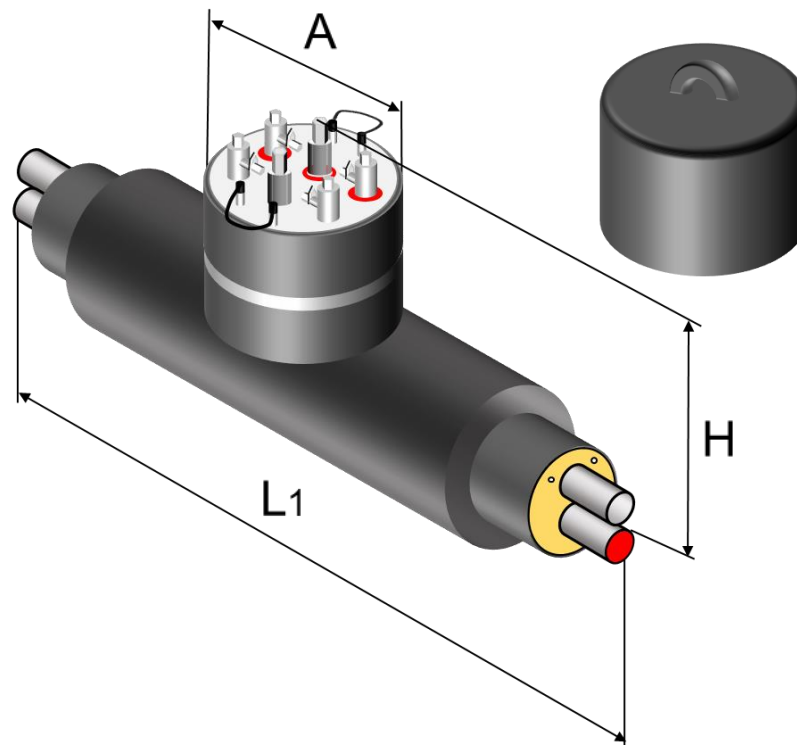

Series 1, 2 and 3

Main pipe DN	L1 [mm]	H [mm]	A [mm]	Wrench size [mm]
25	2300	409	295	19
32	2300	422	295	19
40	2300	435	295	19
50	2400	451	295	19
65	2400	463	295	19
80	2600	483	295	19
100	2800	519	295	27
125	3200	540	340	27
150	3400	578	415	27
200	3600	652	450	50

Tower construction in stainless steel.

Preinsulated combination valve

4.4.3.

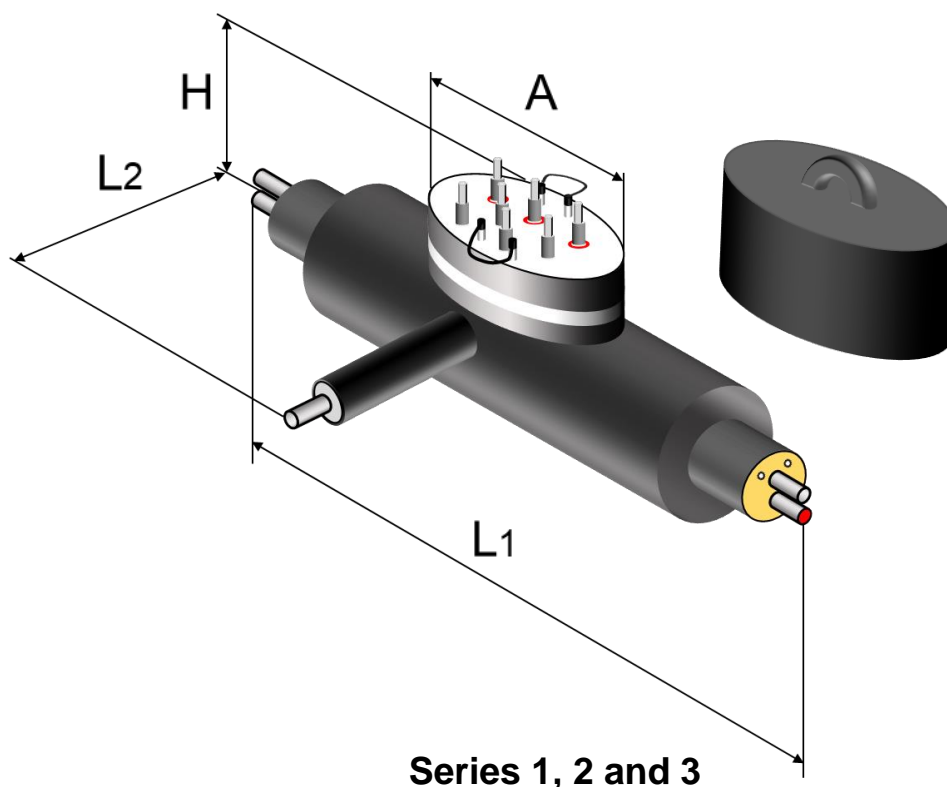

Main pipe DN	L1 [mm]	L2 [mm]	H [mm]	A [mm]	Wrench size [mm]
25	2300	700	409	700	19
32	2300	700	422	700	19
40	2300	700	435	700	19
50	2400	700	451	700	19
65	2400	700	463	700	19
80	2600	700	483	700	19
100	2800	700	519	700	27
125	3200	700	540	700	27
150	3400	700	578	700	27
200	3600	900	652	900	50

Tower construction in stainless steel.

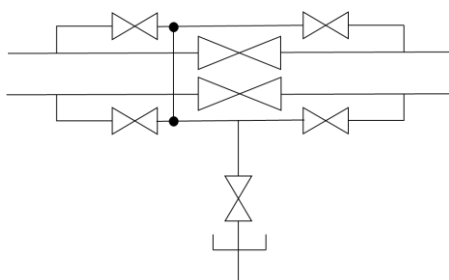

Preinsulated compact valve

4.4.4.

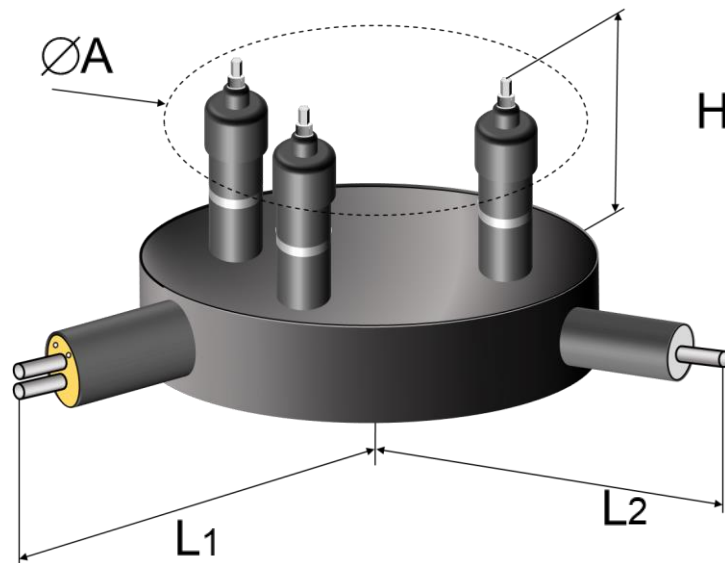

Series 1, 2 and 3

Main pipe DN	H [mm]	A [mm]	L1 [mm]	L2 [mm]
25	382	445	850	520
32	388	465	965	560
40	401	490	885	570
50	406	510	1055	610

Drain release pipe is made of stainless steel.

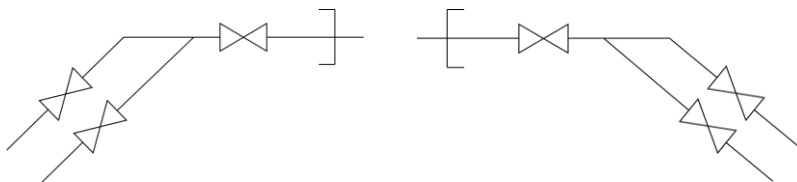

right

left

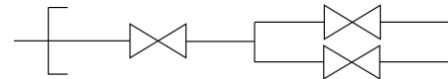

straight

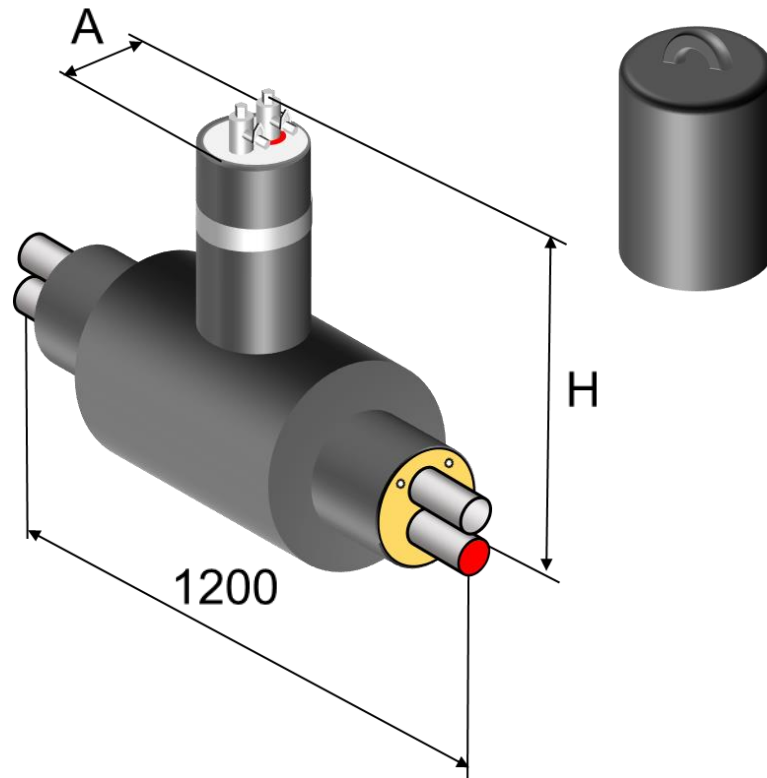

Series 1, 2 and 3

Main pipe DN	H [mm]	Air vent/drain DN	A [mm]
40	451	25	310
50	463	40	310
65	479	50	324
80	495	65	340
100	520		
125	548		
150	581		
200	634		

When making an order it is possible to agree on unit height **H**.
Tower construction in stainless steel.

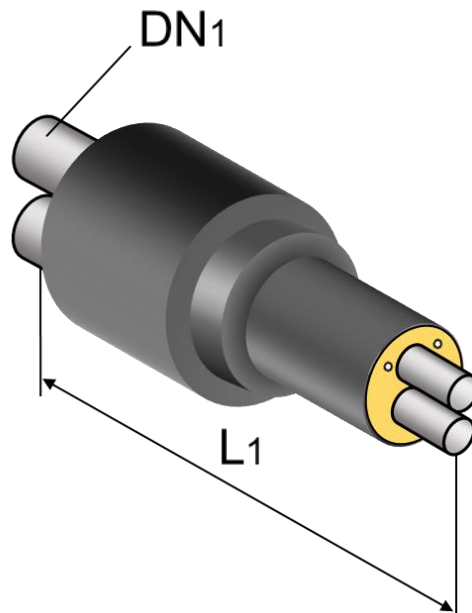

Series 1, 2 and 3

Main pipe DN1	L1 [mm]
32 – 100	1100
125 – 200	1300

Can be ordered with diameter reduction between 1-3 dimension levels.



**Double expanded
shrinkable joint**
L = 700 mm



**Double expanded
shrinkable extended
joint**
L > 700 mm

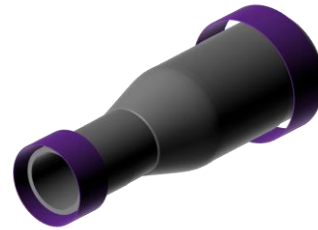

**Double sealed
reduction joint**
L = 900 mm



Baloon joint
L = 900 mm



Baloon joint
L = 1 400 mm



Mittel joint
L = 700 mm
split open / not split open

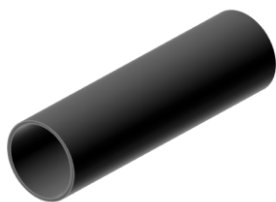

Mittel joint
L ≥ / ≤ 700 mm
split open / not split open



**Double sealed
joint**
L = 700 mm



**Double sealed
extended joint**
L > 700 mm

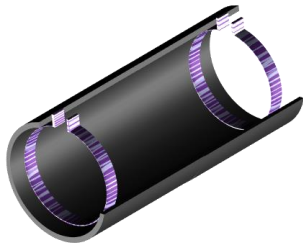

Electro welding joint
L = 700 mm



Heat shrinkable flexible joint
L = 815 - 1 225 mm



T – joint flexible
L = 1000 - 1200 mm



T – joint straight
L = 700 mm

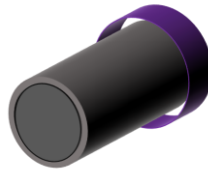

Double sealed Termination joint
L = 700 mm

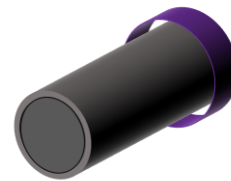

Double sealed extended termination joint
L > 700 mm



Measure joint
L = 700 mm



Double sealed baloon joint
L = 900 mm



Double sealed extended baloon joint
L > 900 mm



T – joint for connection single/double
L = 900 mm

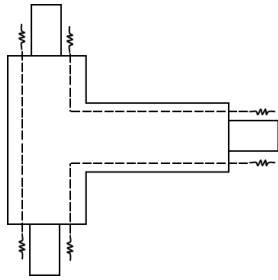

T – piece

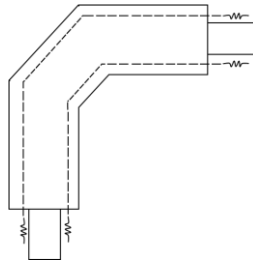

Bend

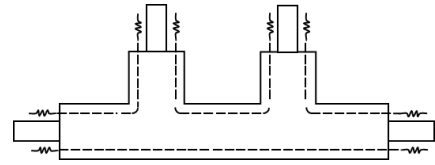

T – piece, double/single

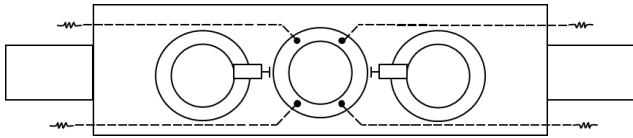

Valve
drain/air release

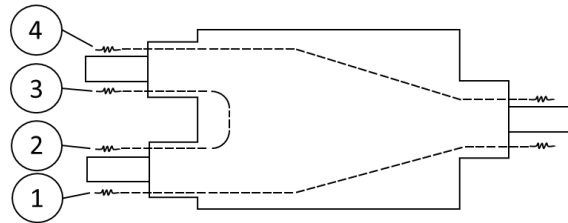

Transition unit, straight
1; 2 or 3; 4 should be looped

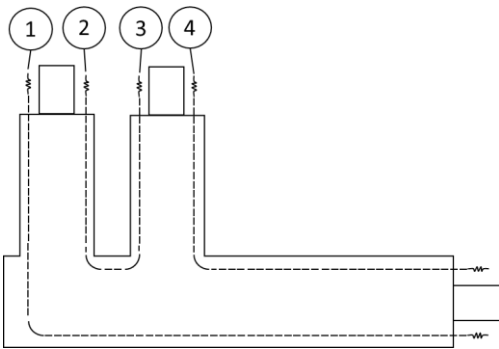

Transition unit angled
1; 2 or 3; 4 should be looped

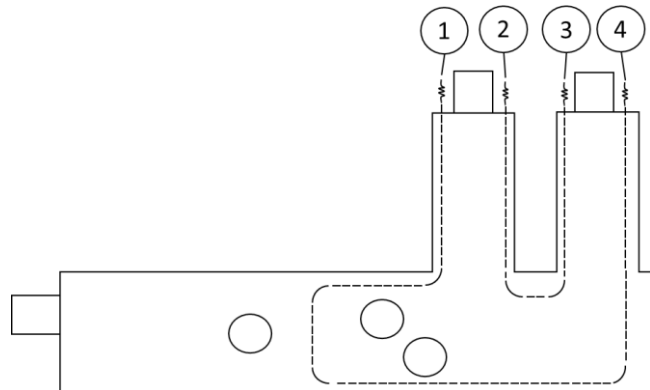

Valve unit – angled
1; 2 or 3; 4 should be looped

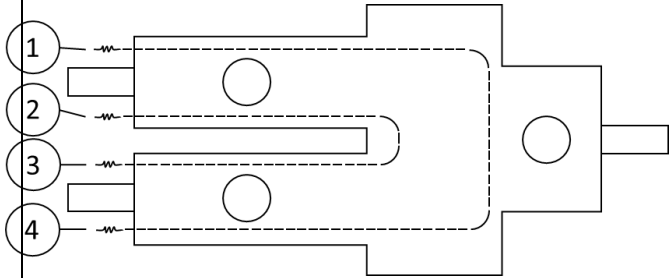

Valve unit – straight
1; 2 or 3; 4 should be looped

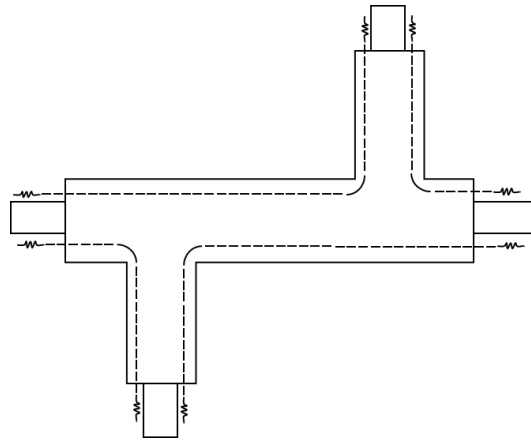

Cross double T – piece

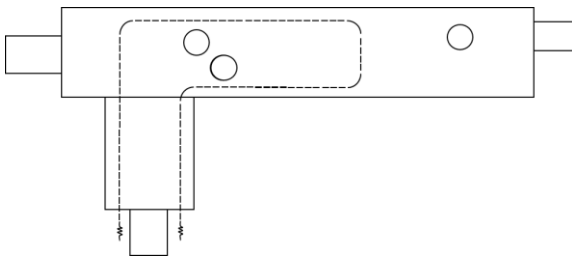

Valve unit double pipe

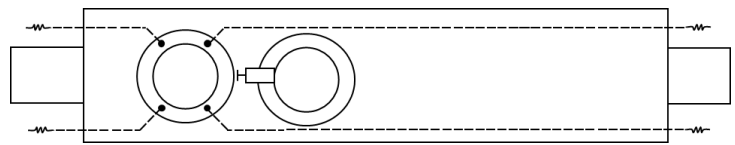

Measuring box earth connection

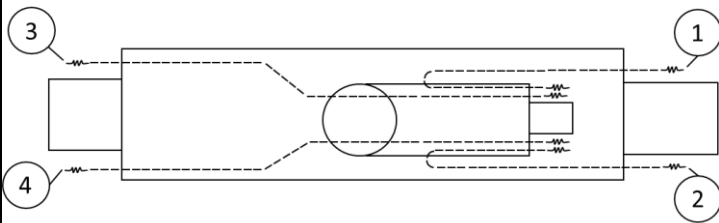

T – piece parallel
1; 2 or 3; 4 should be looped

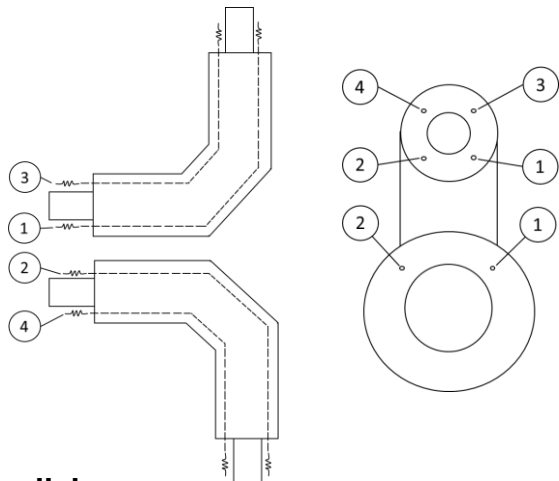

Alarm wire length for each product

*Lengths are calculated from steel pipe end.

Valve	DN 25 – 125	DN 150 – 250	DN 300
Drawn			
Alarm wires	2,3 m	2,5 m	3,0 m
Standard	1,5 m	1,5 m	1,5 m
Transition Unit – straight	DN 25 – 50	DN 65 – 150	
	L = 1400 mm	L = 2250 mm	
Wire 1,3	1,4 m	2,3 m	
Wire 2	0,8 m	0,9 m	
Transition Unit – angled	DN 25 – 40	DN 50 – 100	DN 125 – 150
Wire 1	2,0 m	2,3 m	2,5 m
Wire 2	1,5 m	1,7 m	1,8 m
Wire 3	1,7 m	1,7 m	1,8 m
Valve Unit, angled, single pipe	DN 25 – 80		
Wire 1	1,3 m		
Wire 2	3,7 m		
Valve Unit, straight, single pipe	DN 25 – 80		
Wire 1	1,9 m		
Wire 2	1,4 m		
Parallel T-piece	DN 20 – 400 / DN 20 – 100	DN 125 – 400 / DN 125 – 300	
	L = 1200 mm	L = 1500 mm	
Wire 1, 2, 3, 4	1,4 m	1,7 m	
Valve Unit, straight, twin pipe	DN 25 – 80		
	Wire length 3,3 m		
Valve Unit, angled, twin pipe	DN 25 – 80		
	Wire length 2,3 m		
Measuring box	DN 25 – 125	DN 150 – 250	DN 300
	Assemble depth	Assemble depth	Assemble depth
	+ 0,8 m	+ 0,8 m	+ 0,8 m

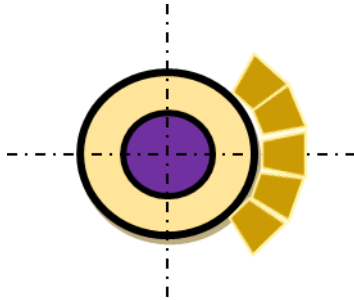

Foam pads

7.1.

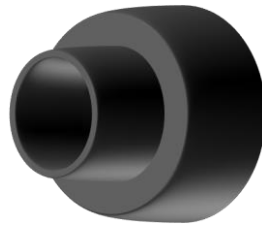

End caps

7.2.

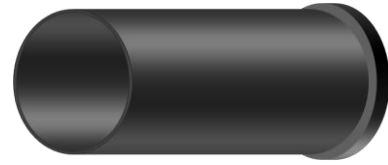

End seal

7.3.



**Elastic seal
F802**

7.4.



Warning tape

7.5.

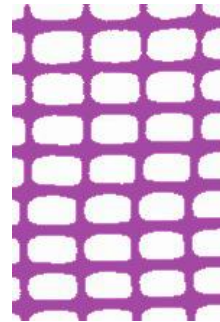

Warning net

7.5.

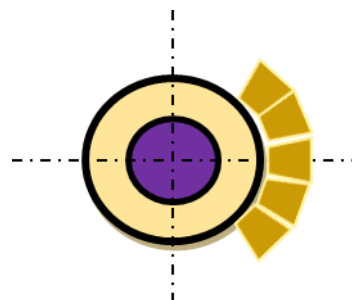
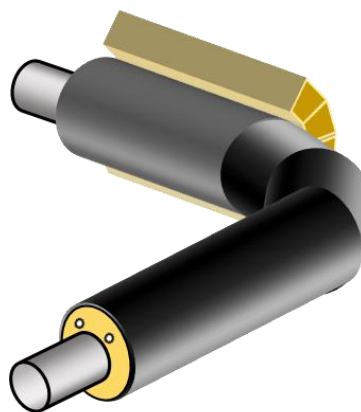
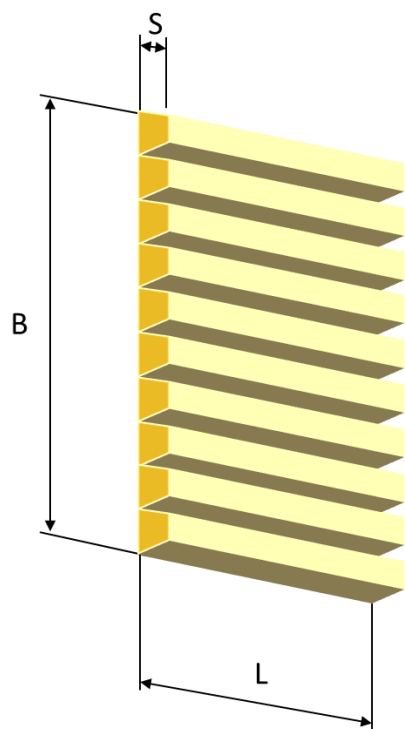

Length L [mm]	Width B [mm]	Thickness s [mm]
2000	1200	50

Foam pads are placed to capture deformation of thermal elongation of the straight pipeline. Pads are produced from flexible material.

Foam pads are placed at the end of straight pipe segments on the outer and inner side of the fitting and are strengthened using duct tape, cord, or any material of such sort.

Foam pads are cut by outer diameter of pipe casing:

Diameter of PE casing [mm]	Width of pad C [mm]	Diameter of PE casing [mm]	Width of pad C [mm]	Diameter of PE casing [mm]	Width of pad C [mm]
90	143	225	300	500	715
110	166	250	333	560	790
125	182	280	370	630	870
140	200	315	430	710	1000
160	222	355	500	800	1130
180	250	400	570	900	1400
200	285	450	665	1000	1500

End cap is heat-shrinkable product that has cylindrical gradually degreasing shape.

End cap is placed at pipe ends to seal PUR insulation after entering buildings, foundation or canals.

End cap are used for one preinsulated steel pipe as well as for preinsulated twin steel pipe system.

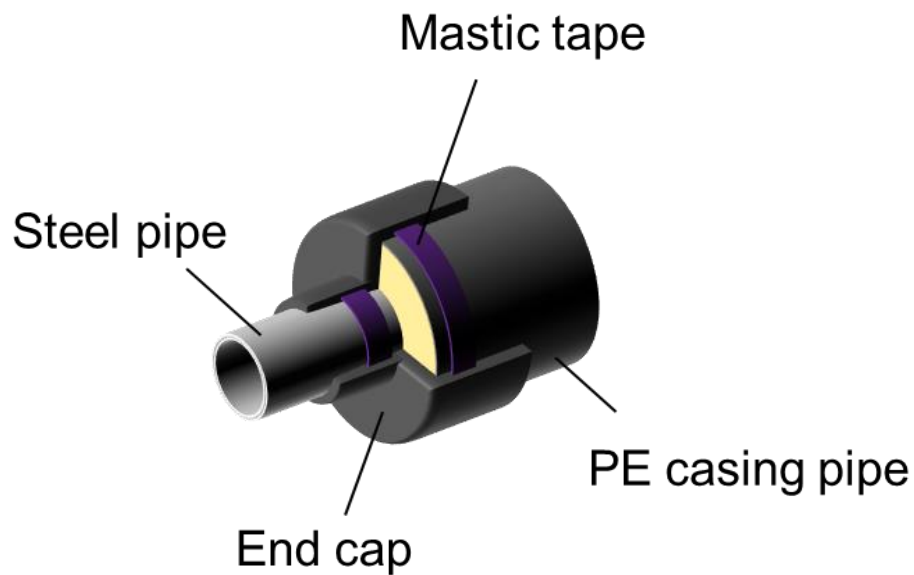

End caps are used for preinsulated pipes with heating pipe temperature not exceeding 135°C.

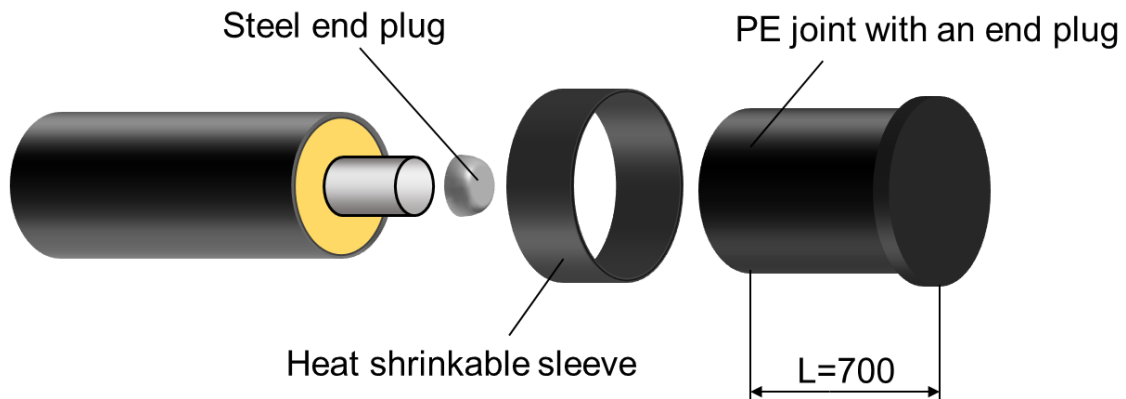

End plugs are used for sealing preinsulated pipe ends that can be extended in the future.

PE sleeve connection to end plug and pipe casing is secured using heat-shrinkable tape. Space under the PE sleeve is filled with rock wool.

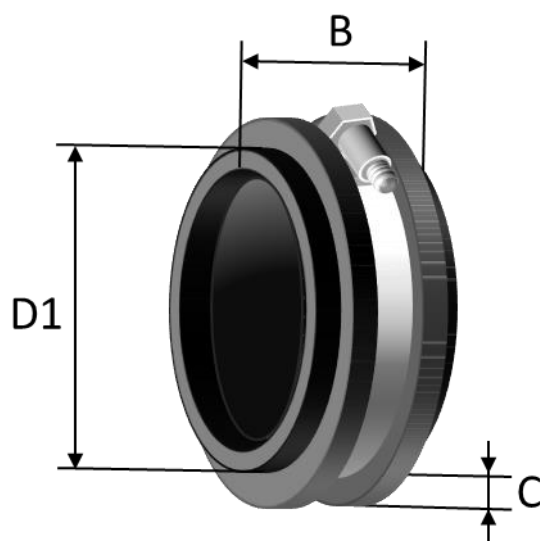

Dimension D1 [mm]	B [mm]	C [mm]
90 - 180	40	22
200 - 1000	50	27

Wall entry rings are used where pipes pass through walls or floor entries to prevent the penetration of ground water in buildings. Rings are made from special rubber profile resistant to ageing.

Location of the F802 in concrete If holes is to be drilled in the concrete wall for later embedding of pipes/rubber ring in concret.

Recommend min. drill holes:

HDPE 40 – 180	Jacket dim.	+ 100 mm
HDPE > 200	Jacket dim.	+ 120 mm

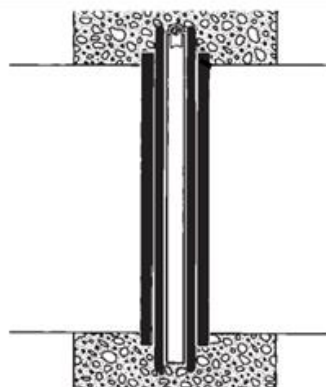

Position between the wall and pipe

When mounting in other types of holes, there should be a clear space above the rubber ring of 20 mm.



Warning Tape

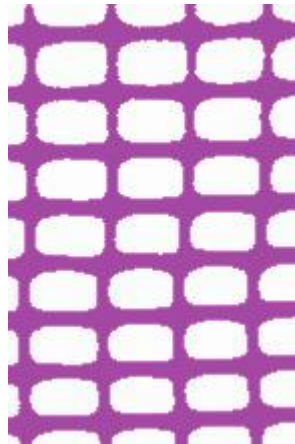

Warning net

Warning tape and net is used to warn and locate the pipeline during earthwork.

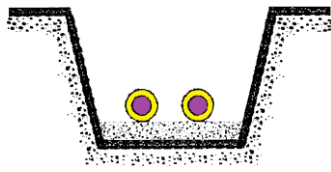

Trench excavation and pipe placement

8.1. – 8.1.2.

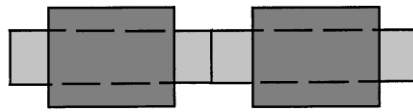

Cutting of the preinsulated pipe

8.2.

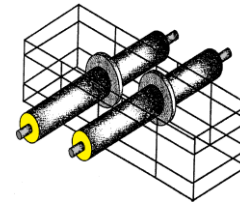

Fixed anchor assembly

8.3.

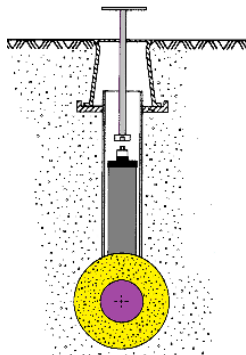

Preinsulated valve assembly

8.4.

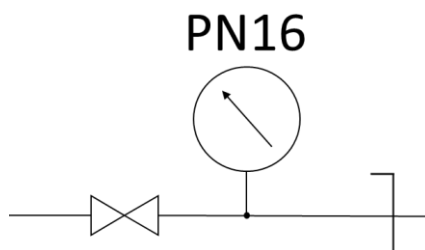

Hydraulic testing

8.5.

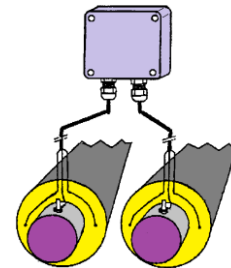

Alarm system assembly

8.6. – 8.6.2.

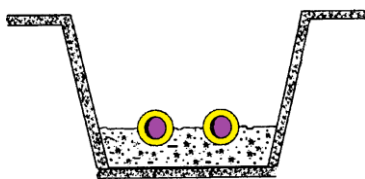

Backfilling of the trench

8.7.



Warranty obligations

8.8.



Chemicals for joints

8.9. – 8.9.1.

Trench excavation and pipe placement

8.1.

Industrially coated heating main construction works should be carried out according to design documentation and "Poliurs" Ltd. Heating main assembling direction CV4.04. Installation work personnel should be trained and certified, according to existing safety requirements.

A. Trench cross section of two-way pipe system

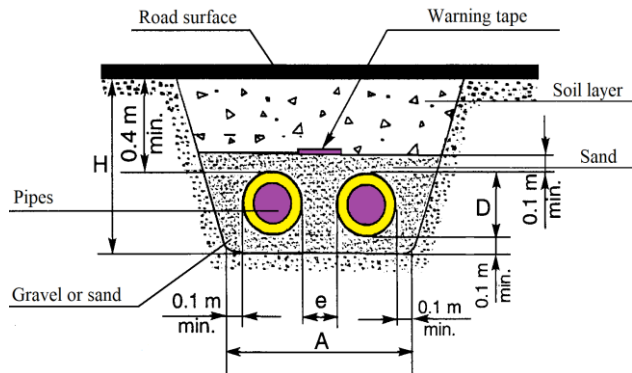

B. Twin pipe trench

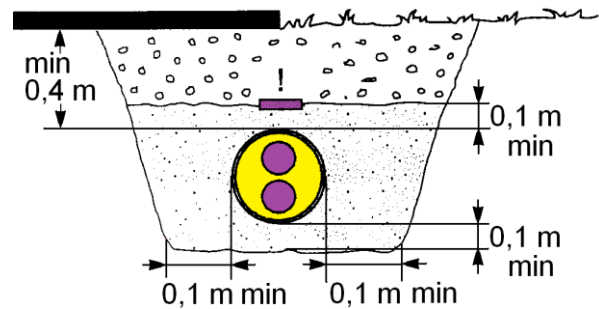

Two-way pipe system trenches cross section suggested dimensions:

PE casing [mm]	Distance between pipes e [mm]	Trench base width A_{min} [m]	Trench depth H [m]
90	150	0.7	0.65
110	150	0.7	0.65
125	150	0.7	0.65
140	150	0.8	0.65
160	150	0.8	0.70
180	150	0.9	0.70
200	150	0.9	0.75
225	200	1.0	0.80
250	200	1.1	0.80
280	200	1.1	0.85
315	200	1.2	0.90
355	200	1.3	0.90
400	200	1.4	1.00
450	200	1.5	1.00
500	200	1.6	1.10
560	200	1.8	1.20
630	200	2.0	1.30
710	250	2.2	1.40
800	250	2.4	1.50
900	300	2.7	1.70
1000	300	3.0	1.80

Trench excavation and pipe placement

8.1.1.

Pipe depth shall be chosen depending on surface loads, construction technology and public utility network location, possible ground agricultural cultivation etc.

In case of major external top loads (for example when it is located underneath or is crossing auto road) over the pipes is placed reinforced concrete plate for better load distribution. Another possible protection for preinsulated pipes is putting protectors onto the pipe and pushing it through already existing corrosion resistant pipe. Protectors are base relief on PE casing, which protect the casing from damages while moving axially.

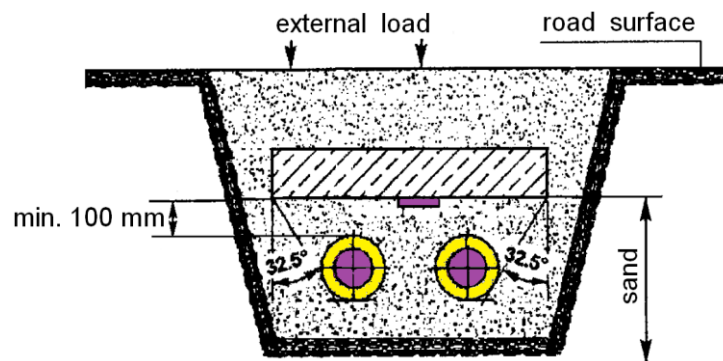

The length of the load distributor should exceed the length of the pipe section to be protected at least 1 m.

Pipes before welding can be placed directly in the trench or on supports above the trench. Pipes in the trench are placed on supports or on sand cushion.

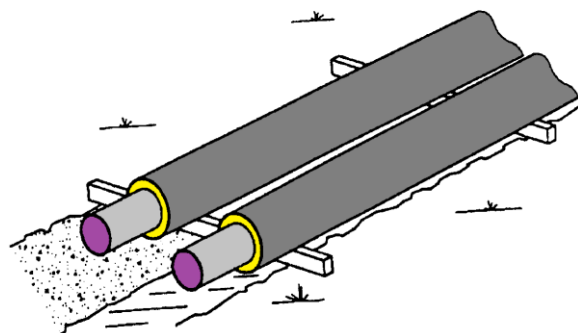
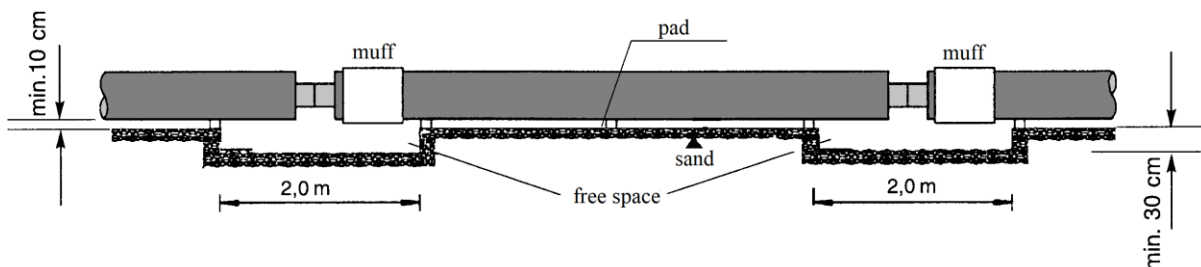

If pipes are located above the trench then after the welding, hydraulic testing and placement of connecting sleeve pipes should be lowered into the trench using lifting straps.

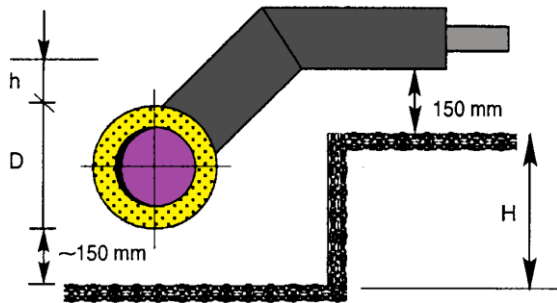

If main heating pipeline is deep enough, then fitting branch can be placed with an uplift and then trench will be deeper by **H**:

$$H = D + h,$$

If the depth of the main heating pipeline is not deep enough, then T-piece should be diverted to the bottom and piece trench should be deeper then **H**.

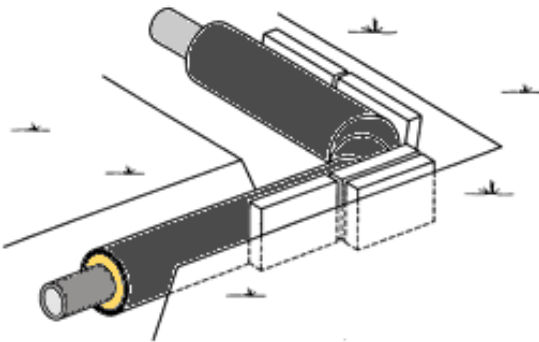

In places where **compensation pillows** are placed, trench width should be increased, depending on pillow amounts and location.

Trench widening shall comply with compensation pillow length and thickness.

The welder should be certified according to the EN 287 standard and according to technology, which corresponds to EN ISO 15607 demands.

Before steel pipe welding, on cover pipe should be put on cylindrical polyethylene (PE) sleeves, which are used for connection assembly.

To avoid damage of burning of the isolation material, ends of the pipe should be covered or protected, for example with aluminum protectors. Protective materials should be removed right after the welding is done and sleeve should get moved over the joining line.

After welding of the steel pipe check PE sleeve before placing it over the joining line.

Before assembly, while performing assembly and after, it is required so that pipes from inside would be clean, dry and would not contain any foreign materials.

If after performing assembly pipes require cleaning, then rinse them with water.

If it is required to shorten the length of the preinsulated pipe or is required to have fixed length pieces, proceed accordingly:

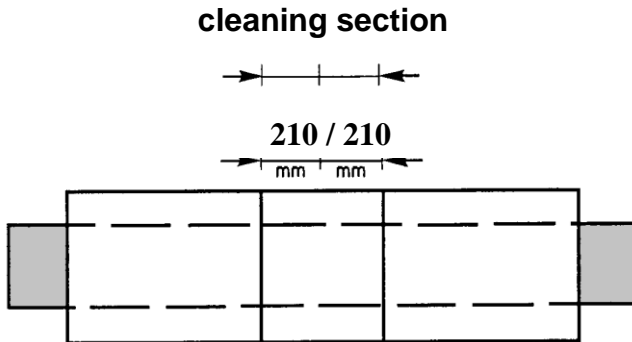

1. On polyethylene casing mark cutting place and from it on both ends (distance of 200 to 250 mm) clean section from insulation.

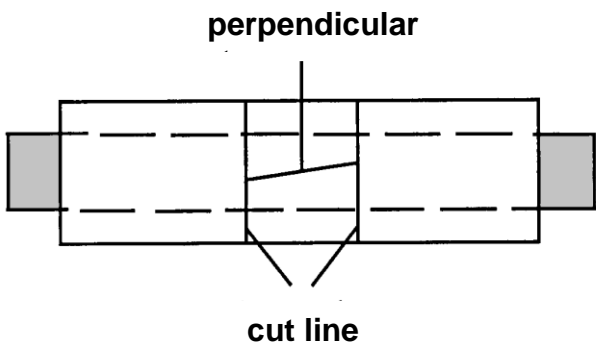

2. Cut the pipe in the market place along pipe circumference. With sloped ring cut the casing removable portion. Remove cut out casing section.

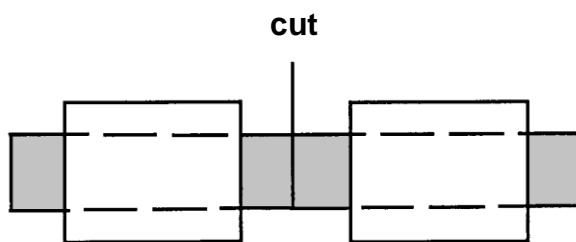

3. Remove carefully the foam from the middle section with the knife so that wires stay untouched. Cut alarm system wires. Clean all foam insulation up to pipe casing. It is unacceptable to have any sort of damage done to the wires while cutting, pulling, etc.

Cut main heating pipe. Cutting with gas torch, it is required to protect casing pipe and polypropylene (PUR) isolation from overheating. Clean ends of the heating pipe from foam leftovers. Cut pipe at the designated spot.

Industrially produced fixed anchor consists from 2-3 m long preinsulated pipes, where in the middle, next to the work pipe, assemble steel flap (cap, facing).

During assembly procedure set up an anchor block from reinforced concrete around fixed support facing (flange, top). Concrete anchor strength secures assembly steel frame.

The fixed anchor undergoes the great load during the pipeline lifetime; therefore, it is needed to install them in the dense rammed soil.

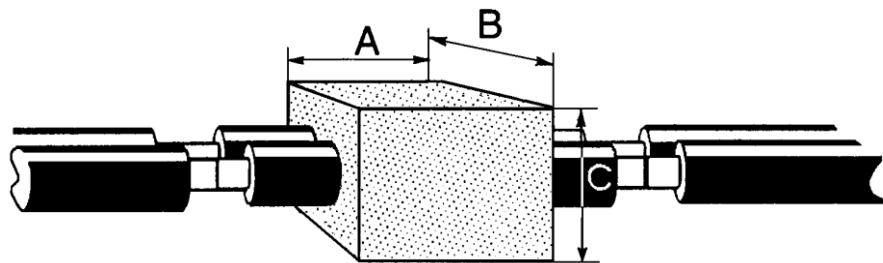

Suggested anchor block sizes:

Main pipe DN	Anchor size [m] A x B x C	Rebar diameter [mm]
32	0,5 x 0,7 x 0,5	8
40	0,5 x 0,7 x 0,6	8
50	0,7 x 1,0 x 0,6	12
65	0,7 x 1,0 x 0,6	12
80	0,7 x 1,0 x 0,6	12
100	0,8 x 1,5 x 1,1	12
125	1,0 x 1,5 x 1,2	12
150	1,0 x 2,0 x 1,2	20
200	1,0 x 2,3 x 1,4	20
250	1,2 x 2,7 x 1,4	20
300	1,2 x 3,0 x 1,4	20
350	1,2 x 3,3 x 1,5	20
400	1,2 x 3,5 x 1,5	20
450	1,2 x 3,8 x 1,7	20
500	1,2 x 4,0 x 1,8	20

Pipeline operation could only begin after complete concrete curing.

Isolated spherical valves, isolated valves with air or drain release/ drainage are installed into heat main the same as other fittings or straight pipe sections-after welding of the work pipe and isolating joining places. Assembling (fitting) diagram must ensure convenient access to valve operating mechanism and safety against damages of the mechanism while operating.

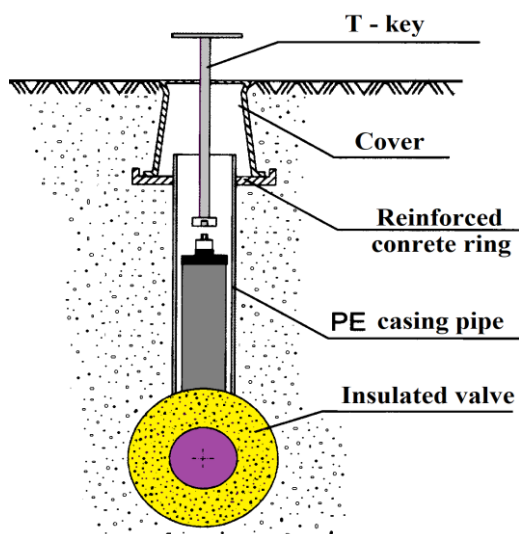
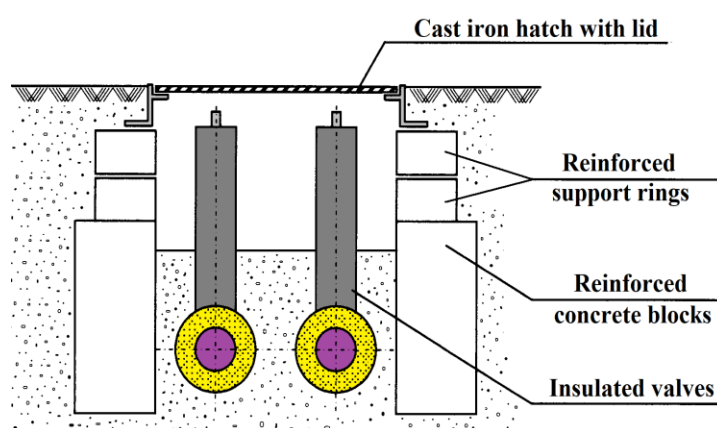
Version A.**Version B.**

Isolated valve assembly is chosen from taking into account surface loads, engineering works, municipal network location, etc.

Example A is used when surface loads are minimal (for example sidewalk, green territory), example B - at greater surface loads, for example road or freeway.

While performing assembly works valves must be in open position, in that way minimizing probability of sealing damages.

From the ground surface valve is opened and closed using T-shaped key, which come in the package. Reinforced concrete products and iron manhole covers „Poliurs” Ltd. does not provide.

After assembly of the line and rinsing of the valve it is recommended to perform first closing of the valve by turning T-shaped key in counterclockwise direction for 90°, afterwards closing the valve by turning the key in opposite direction.

After the non-destructive testing of the welding; pipeline undergoes the hydraulic control, recommended in several steps, with pressure that exceeds maximum service pressure 1.3 times but not less than 16 bar.

Testing should be made with customer presence and supervision. About testing results should be composed record (protocol).

Cold water should be used for hydraulic testing. The control pressure duration should take at least 15 minutes.

Testing pressure cannot be decreased for more than 5% from initial testing pressure.

During testing, assembly stitch cannot show any moisture.

If the leak is found, then appropriate welding place should be cut out and repeatedly welded. Hydraulic testing should be repeated.

Testing section should be disconnected from already working pipeline using seals.

The hydraulic testing should be carried out after welding of all connecting units, but before assembly of the sleeves.

If the casing pipe or the service pipe is damaged, there is a danger of humidity getting into the heat insulation layer, which could destroy the heat insulation of the pipes, as well as the untimely corrosion of the steel pipes.

The alarm system is installed in the preinsulated pipes and the joints, which enables to recognize the humidity in the heat insulation layer.

Two copper not isolated wires are installed in the heat insulation layer of the pipe on opposite sides of the pipe.

Place pipes in such way that alarm copper wires are located parallel to each other.

Free wire ends that are not isolated should be protected against any damage.

According to project scheme, alarm system assembly should be performed before isolation of the connection is poured between pipes. Assembly of alarm system wires in unfavorable weather is forbidden.

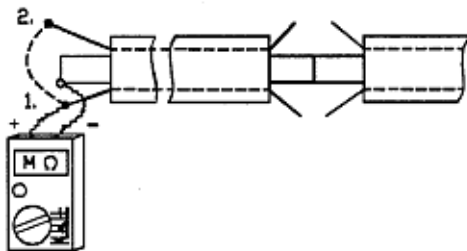

1. Begin assembly of alarm wires from one end, at the same time check resistance in already connected segments. Before connecting to the united alarm circuit should check with megohmmeter each pipes and joints isolation resistance and resistance of the alarm system wires. The resistance of the insulation should be greater than 100 MΩ

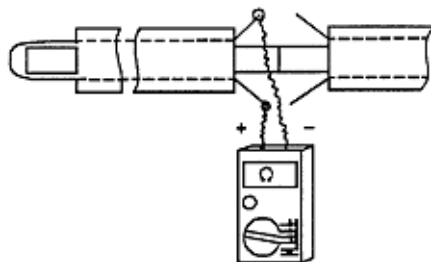

2. Connect wires in the loop in such way that they don't come in contact with steel pipe and check it for resistance. Results should be registered in the assembly journal.

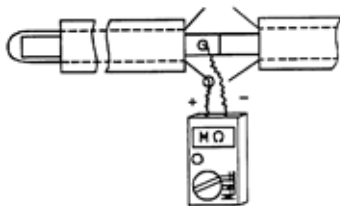

3. Continue checking wire resistance as you connect more and more pipes into the loop. Continue recording your results in the journal.

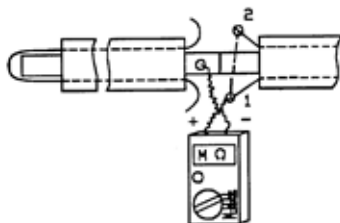

4. In article 1 mentions insulation resistance should be greater than 100 MΩ
5. After checking for resistance connection of alarm system wires is performed in such steps:

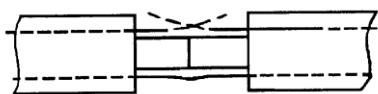

Cut straightened wire ends so that after connection they are not hanging. Wire ends of approximately 1-2 cm should be cleaned carefully with sand paper.

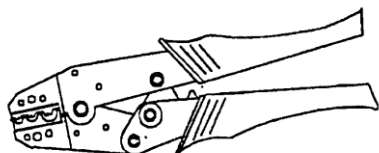

Insert one end of the wire into the splicing pliers and compress it with special tongs.

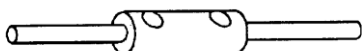

Insert and compress the other wire end. Connection is brazing with the special splicing sleeve.

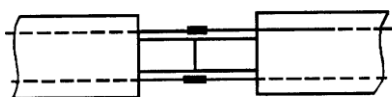

Connect wires at the other end of the pipe the same way.

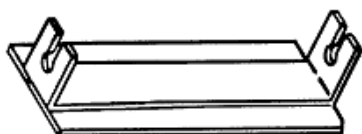

For wires not to touch steel pipes they are secured with special wire holder.



Place wire holders symmetrically and attach them to steel pipe with duct tape.

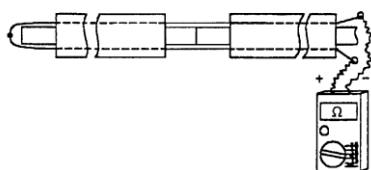

6. Insulation, wire loop resistance and wire connection check should be performed at every pipe connection. Record all readings taken in the journal.

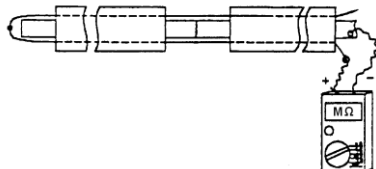

100 m long wire resistance should be $1,3 \Omega \pm 15\%$.

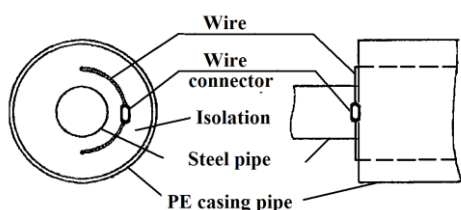

7. At the end of the pipe network where pipes are not going to be connected to further connected pipes should be connected in a loop and should be secured to the insulation, eliminating any chance of contact with steel pipe.

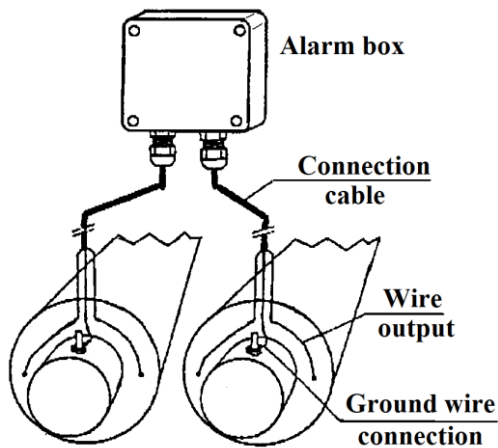

8. Control and measurement of alarm system wires is possible by connecting wires to the alarm box with the help of 3 lead connection cables. Cable main wire should be connected to the steel pipe with help of screw M8 and a wrench. Alarm boxes are installed close to the pipes entry in the house and/or heating chamber.

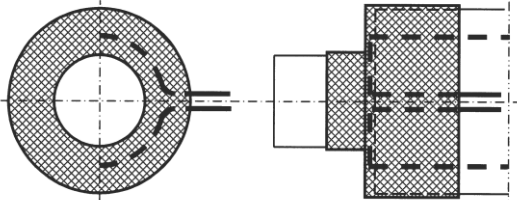

It is advised to place shrinkable cap at the end of the pipe to protect PUR insulation and alarm wires. Also, connect joining cable to alarm wires underneath the cap.

Alarm system should be supervised at all time with acquired monitoring equipment. Impulse reflection method is used for specific incident place determination. Such equipment is available at „Poliurs” Ltd.

After alarm system assembly and testing the supervisory alarm acceptance act should be filled out. Keep in storage installation act and journals.

Place pipes on compressed sand foundation, keeping track of spacing between pipes and spacing from trench sides –see 2nd section. Place compensation pillows according to designed specification.

Remove from the trench temporary supports and any other objects.

Fill up the trench by adding layers gradually. Before adding following layer, first compact previous one. Maximal thickness of one layer if non mechanical compaction is performed – 150 mm, if mechanical then 300 mm.

Depending from designed thermal deformation compensation method, available 2 (two) trench backfilling versions:

- 1) fill up the trench when pipes are in cold state;
- 2) previously loading (heating) pipes before filling of the trench.

1st version First, cover pipes from the sides and gap between the pipes, until level of layer doesn't reach 100 mm above pipes. Use sand that does not contain any rocks, metal pieces, floral leftovers, soil and stone pieces. Perform non-mechanical compaction. Place caution tape at the designed depth (not less than 100 mm about preinsulated pipes) and secure it by covering with sand.

For preinsulated pipes with diameter ≥ 200 mm is recommended to place caution tape above every pipe, heating and return. If preinsulated pipe diameter is < 200 mm – place one caution tape above both of the pipes. The rest of the trench fills with earlier excavated soil. Mechanical compaction can be performed after trench filling is 200 mm above preinsulated pipe.

If compensators or fixed anchors are used then no special backfilling demands are required.

2nd version

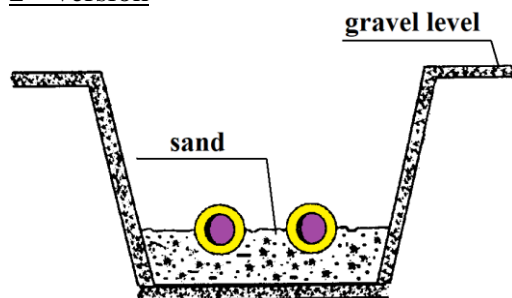

In section where thermal pressure is present, compact that area with sand up to the center of preinsulated pipes (see drawing). Mechanical compaction is not allowed.

Heating main needs to be completely filled up and compacted after the designed temperature is reached.

If heating main is planned to be pressurized using base compensator, then cover pipes and compress the trench while pipes are in cold condition; ends need to be left free where thermal deformation compensation is predicted – compensator and heating main turns within $60^\circ \div 90^\circ$. When heating main is heated up to the designed pre-pressurized temperature and base compensator finished working then weld the compensator out from the pipe line. Fill and compact remaining part of the pipe line while keeping pre-pressurized temperature. After filling up of the trench perform environmental improvements to the area where pipeline is buried: plant trees or other green plants, street or sidewalk restoration, etc.

"POLIURS" Ltd. ensures, that industrially preinsulated pipes and fittings fail-safe life is 5 (five) years, if Customer fulfilled these conditions:

- taken into account transportation, storage, assembly and exploitation requirements that are explained in this instruction;
- ensures following pipeline parameters:
 - working pressure $\leq 16; 25$ bar;
 - temperature $\leq 140^{\circ}\text{C}$;
 - salinity < 3000 mg/l;
 - pH 9,5 -10;
 - free oxygen not permissible.

"POLIURS" Ltd. warranty on alarm system wires is effective, if customer filled out and kept alarm system assembly testing act and alarm system acceptance acts.

"POLIURS" Ltd. issues warranty certificates on its products.

POLYOL (Component A)

Extract from Safety Data Sheet VI4.01

1. Ingredients:

Cyclopentane, CAS No.287-92-3

Polypropylene glycol, CAS No.25322-69-4

N, N-dimethylcyclohexylamine; CAS - № 98-94-2

Hazards identification: The product is not classified as dangerous.



2. Characteristics of exposure:

Contact with the substance may cause respiratory, skin and eye irritation if swallowed - feeling sick, vomiting, discomfort.

3. Work safety regulations.

Hand protection: rubber or plastic gloves

Eye protection: safety glasses with side-shields.

Body protection: closed work clothes

Safety and hygiene measures: Do not eat, drink or smoke when handling the product. Wash hands and face before breaks and after replacement.

Storage: separate from food and feedstuffs. Store in tightly closed containers in a dry place at a temperature of + 15 ÷ 30oC. Avoid unauthorized access and unintended mixing with isocyanate.

4. First aid.

General advice: Dispose of soaked clothing.

Inhalation: If problems occur after inhalation of vapors / aerosols: fresh air, seek medical advice if discomfort persists.

Skin contact: Wash thoroughly with soap and water.

Eye contact: When lifting eyelids, wash eyes with plenty of water for at least 15 minutes, consult a specialist if discomfort persists.

If swallowed: Do not induce vomiting. Drink plenty of milk or water, seek medical attention.

Do not allow product to reach ground water. Absorb spillage with sand, etc. materials. Dispose of in accordance with local authority requirements.

5. Fire-fighting measures.

The product is flammable, not highly flammable. Use foam, powder or water vapor for extinction. After extinguishing, cool containers and unburned products thoroughly with water. Use self-contained breathing apparatus when extinguishing.

6. Additional information: Safety data sheet VI4.01

ISOCYANATE (Component B)

Extract from Safety Data Sheet VI4.02

1. Chemical composition:

Diphenylmethane diisocyanate, isomers and homologues
CAS no. 9016-87-9



2. Characterization of exposure.

H332 - Harmful by inhalation,
H319 / 334/315 - Irritating to eyes, respiratory system and skin.
H317 / 335 - May cause sensitization by skin contact.
H351 - Limited evidence of a carcinogenic effect
H373 - Harmful: danger of serious damage to health by inhalation long-term exposure.

3. Work safety regulations.

Hand protection: Moisture-proof gloves.

Eye protection: Tightly fitting safety goggles.

Body protection: Protective clothing, closed work clothes.

General safety and hygiene measures: Keep away from foodstuffs, feedstuffs and beverages. Do not eat, drink or smoke in the workplace. Wash hands and face before breaks and after shifts.

4. First aid.

If inhaled: Remove person to fresh air and keep warm, allow to rest; if breathing is difficult, seek medical attention.

In case of skin contact: In case of skin contact, it is recommended to wash with a cleaning agent based on polyethylene glycol or with plenty of soap and water. Consult a doctor in case of skin reaction.

In case of eye contact: Keep eyes open and rinse with lukewarm water for a sufficient period of time (at least 10 minutes). Contact an ophthalmologist.

If swallowed: Do not induce vomiting; seek medical advice.

Note to physician: Treat symptomatically (detoxification, vital signs), no specific antidote is known, a dose of corticosteroid aerosol should be used to prevent pulmonary odema (dexmatazone).

5. Fire-fighting measures.

Suitable extinguishing media: dry chemical, foam, carbon dioxide (CO₂), water spray.
The following substances can be used to extinguish the flame: carbon monoxide (CO), carbon dioxide (CO₂), nitrous oxide, hydrogen cyanide, isocyanide.

Special protective equipment: Wear self-contained breathing apparatus and protective suit.

6. Additional information: Safety data sheet VI4.02.

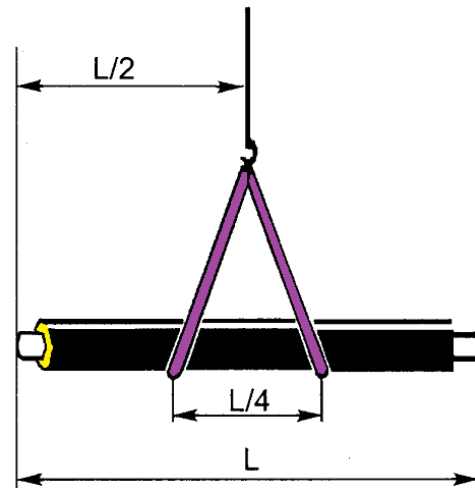
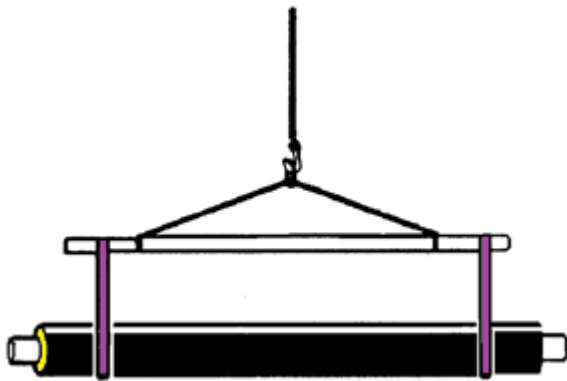

Lifting straps must be at least 60 mm wide.
Preinsulated pipes should be stored in trapezoid or square shapes.

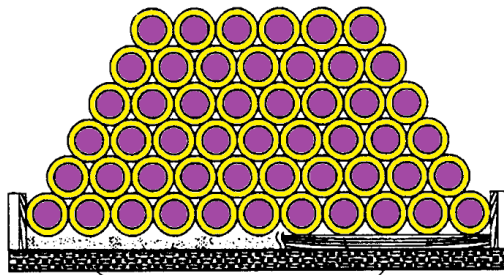

support

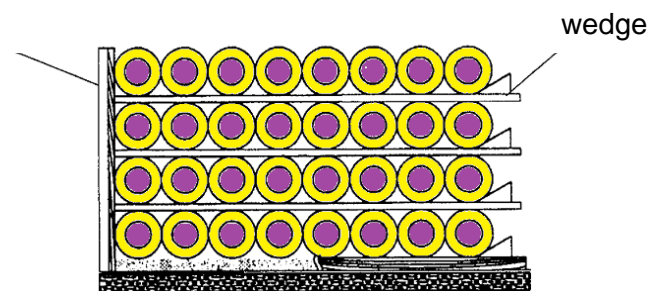

wedge

Sand or wooden sleepers

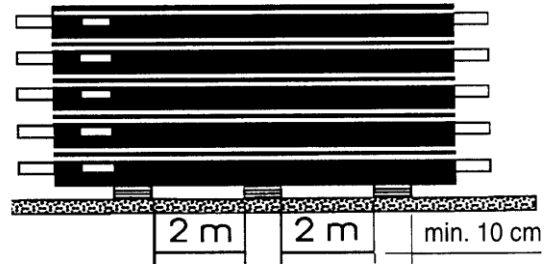
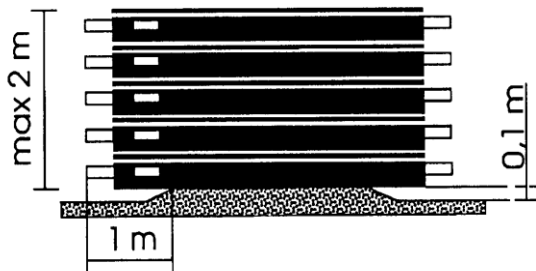

To prevent the polyethylene casing pipes from damage:

- during the piling works any wire ropes, chains, wires etc. should not be used;
- pipes should be stacked on the even surface;

Fittings and small parts: couplings, foam pads, heat-shrinkable materials, components "A" and "B", wall entry rings etc. are stored separately in a place protected from direct sunlight. Containers, where the components "A" and "B" are stored, are opened just before use.

Before welding ends of the service pipes, they should be kept closed with caps. If no end caps are available for example after the pipe cutting, end of the pipe should be closed with PE coat (diaphragm, film) or any other suitable material.